



**CHRYSLER**



**Car and Truck**

**Installation Instructions**



*Electrify Your Ride*

## Kwik Wire Would Like To Thank You for Your Purchase



### — Terms and Conditions of Your Purchase —

Buyer's sole and exclusive remedy and Saint Wire & Cable Inc. sole and exclusive liability to buyer here under is limited to repair or replacement, at Kwik Wire option, of the product, sold hereby. Kwik Wire liability, whether based upon warranty, contract, tort or negligence, shall not in any case exceed the cost of correcting defects in the goods as herein provided. Saint Wire & Cable Inc. shall in no event be liable in contract or in tort (including negligence) for special indirect, incidental or consequential damages, such as, but not limited to, loss of property damage, or any other damage, cost or expenses which might be claimed as the result of the use or failure of repair or replacement as above described.

### — Return Policy —

To insure the highest quality products, we must ask that you order only what you need. We do not accept harness returns that have been cut, stripped, crimped, soldered, partially installed, damaged or tampered with while in your possession. Claims for shortages and returns must be made within 30 days of purchase or shipping date. You will need to call Kwik Wire to obtain a return authorization number (RAN) on all returned goods.

Special orders are not returnable. No cash refunds. Items Returned for Credit subject to 20% handling plus repacking charges. This includes products purchased from the company at events. Shipping and handling charges are non refundable.

The need for returns could be eliminated with a phone call to Kwik Wire.

Please call toll free 1-888-994-9913 or local 920-921-2637

**Absolutely NO Returns after 30 Days**

Delayed installations do not extend return privileges.

Absolutely **NO RETURNS** will be accepted at any event after the 30 day period has ended. **Switches, Light bulbs, LED lights**, special orders, and any item that was previously installed are not eligible for a refund.

**Thanks Again!**



- Please read the entire instruction manual before beginning installation. This will save you time on the phone.
- This manual is meant as a general guide to install our kits. You may need to refer to shop manuals, your local library, or the internet for vehicle specific wiring colors and functions.
- This manual applies to all standard and budget kits. Certain wires and connectors may not apply to your installation.
- Not all wires originate at the fuse panel. Several are placed loose within the harness such as #7 Dimmer and #19 Neutral Safety wires. Please refer to wire index pages.
- Please install whole harness before testing as all wires need to be hooked up before proper component operation.
- Disassembling of fuse panel voids your warranty.

# **Notes**

---

---

---

---

---

---

---

---

---

---

---

---

---

---

---

---

---

---

---

---

---

---

---

---

---

---

# **Table of Contents**

6...Parts List  
8...Pre Installation Guide  
9...Fuse Panel Mounting  
10...Factory Wire Diagrams  
11...Motor Group  
13...Charging Systems  
17...Ignition Group Switches  
20...Ignition System  
26...Headlight Group H-1  
27...Horn  
28...Electric Fan  
29...Dome Light  
30...Accessory Group Battery Positive  
33...Instrument Group  
35...Column and Turn Signal Group  
43...Headlight Switch H-2 Group  
46...Dimmer Switch  
47...Radio Group  
48...Cruise Control and Back Up Light Group  
49...Brake Switch  
50...Tail Lights  
51...Tail Group  
52...Fuse Charts  
53...Wire Index  
55...Wire Group Index  
58...Fuse Panel Specifications  
60...Recommended Installation Tools  
62...Terminal Removal  
63...Terminal Crimping  
64...Wire Splicing  
66...Catalog  
72...2019/20 Show Schedule

## Proudly Designed, Engineered & Manufactured in the USA

All of our restoration harnesses are manufactured in the USA with components sourced from US suppliers. We strongly believe in the value of supporting and maintaining American jobs and firmly believe the quality of American made products can't be matched. We have been providing restoration wiring with this mentality since 1991.

We have put together two harness options to fit your project and your wallet which are Budget and Standard. Our budget series is our basic harness with the same quality and workmanship as standard line but do not include some parts or features including: **Coil Kill Switch, Stainless Steel Fuse Cover, Tumbled Aluminum Base Plate, Speaker Wire, and Maxi Fuse.**

Please inspect your harness upon purchase to be sure you have received all of the supporting components that are intended to come with the kit you purchased. Below is a list of components that are included with your wire harness.



- |   |   |   |
|---|---|---|
| <b>1</b> 6" Jumper Red #34 Wire (1)     | <b>7</b> Zip Ties                       | <b>13</b> Grommets (2)                    |
| <b>2</b> Late Model Column Plug—F (1)   | <b>8</b> Push-on Terminals (4) sets     | <b>14</b> Dimmer Switch Connector (1)     |
| <b>3</b> Alternator connector (1)       | <b>9</b> Instruction Manual (1)         | <b>A</b> 1/4" Terminals (12)              |
| <b>4</b> Splices 10-12 (2) 14-16 (8)    | <b>10</b> Ignition Switch Connector (1) | <b>B</b> Headlight Plug (2) Terminals (6) |
| <b>5</b> Ring Terminals (4)             | <b>11</b> Ignition Switch Connector (1) | <b>C</b> 50A MaxiFuse/Conn. (1) TTerm(2)  |
| <b>6</b> Early Model Column Plug -F (1) | <b>12</b> 1" Firewall Grommet (1)       | <b>D</b> Column Plug Terminals—F (11)     |



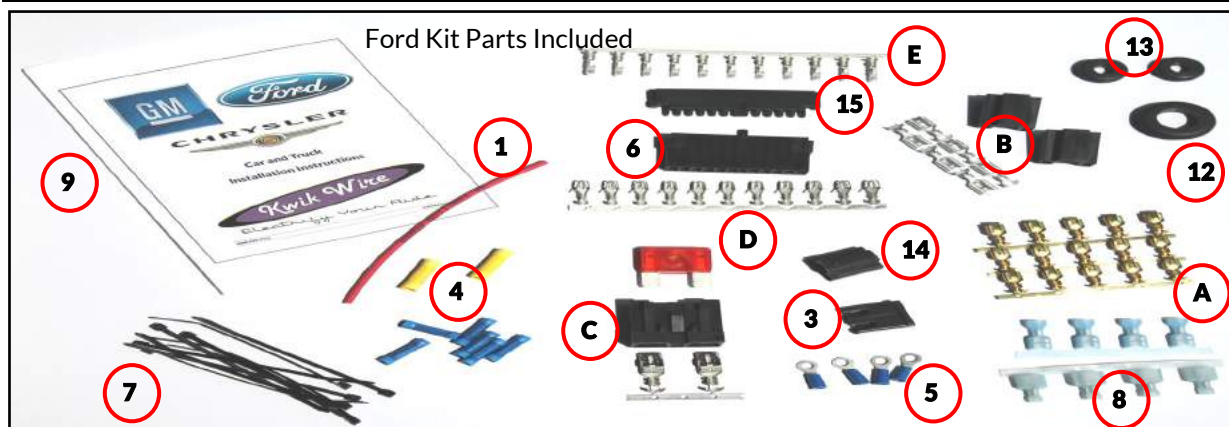

- |  |   |  |
|--|---|--|
| <b>1</b> 6" Jumper Red #34 Wire          | <b>8</b> Push On Terminals (4) Sets       | <b>A</b> 1/4" Terminals (12)                   |
| <b>3</b> Alternator Connector (1)        | <b>9</b> Instruction Manual               | <b>B</b> Headlight Plugs (2) Terminals (6)     |
| <b>4</b> Splices 10-12 (2) 14-16 (6)     | <b>12</b> 1" Firewall Grommet (1)         | <b>C</b> 50A Maxi Fuse /Conn (1) Terminals (2) |
| <b>5</b> Ring Terminals (4)              | <b>13</b> Small Grommets (2)              | <b>D</b> Column Plug Terminals—F (11)          |
| <b>6</b> Early Model Column Plug - F (1) | <b>14</b> Dimmer Switch Connector (1)     | <b>E</b> Column Plug Terminals—M(11)           |
| <b>7</b> Zip Ties                        | <b>15</b> Early Model Column Plug - M (1) |  |



- |  |   |  |
|--|---|--|
| <b>1</b> 6" Jumper Red #34 Wire (1)      | <b>8</b> Push On Terminals (4) Sets     | <b>14</b> Dimmer Switch Connector (1)      |
| <b>3</b> Alternator connector (1)        | <b>9</b> Instruction Manual             | <b>16</b> Mounting Spacers (4)             |
| <b>4</b> Splices 10-12 (2) 14-16 (6)     | <b>10</b> Ignition Switch Connector (1) | <b>17</b> Mounting Bolts (4) Nuts (4)      |
| <b>5</b> Ring Terminals (4)              | <b>11</b> Ignition Switch Connector (1) | <b>18</b> Fusible Link                     |
| <b>6</b> Early Model Column Plug - F (1) | <b>12</b> 1" Firewall Grommet (1)       | <b>A</b> 1/4" Terminals (12)               |
| <b>7</b> Zip Ties                        | <b>13</b> Small Grommets (2)            | <b>B</b> Headlight Plugs (2) Terminals (6) |
|  |   | <b>D</b> Column Plug Terminals—F (11)      |

## — Step by Step Instructions to Wire Your Car —

### **\*\*First Disconnect Battery\*\***

- Read the instruction book and look at all diagrams before starting installation.
  - This instruction book is used for all Kwik Wire harnesses
  - Some wire in the instruction book may not apply to your kit
  - Check your kit to make sure everything is included
  - Lay the harness out on the floor
  - Plan the path to which way your wires will be routed
  - Only remove the ties holding the bundles together
  - Leave all labels on until you have completely installed your kit
  - Kwik Wire kits have been designed to mount according to the instructions found on Page 9. Not following this procedure may result in wires that do not reach the desired destination.
- 

### **\*\*YOU MUST SUPPLY ALL GROUND WIRES / STRAPS\*\***

Grounding kits and straps are available at Kwik Wire

All Fiberglass Body projects should require a grounding kit

#### **3 Ground Straps Minimum Required for proper grounding**

1. Battery to Frame
2. Engine to Cowl/Body
3. Engine to Frame

4 GA. ALTERNATOR TO STARTER JUMPER REQUIRED FOR HIGH OUTPUT ALTERNATOR

---

## — Testing —

Test for any problems that may occur upon installation completion with a 10 amp or small battery charger to ensure safety.

---

**Proceed with installation of your Kwik Wire Universal Street Rod Wiring Harness only after you have read and understand all of the above steps and guidelines.**

---



# Mounting Fuse Panel

**Kits are designed for driver side mounting to firewall as shown below.**

**\*Alternate mounting locations could be passenger side, glove box, or under a seat but the wire lengths will be too short or too long in certain areas. All wire is available for sale per foot for extensions.**

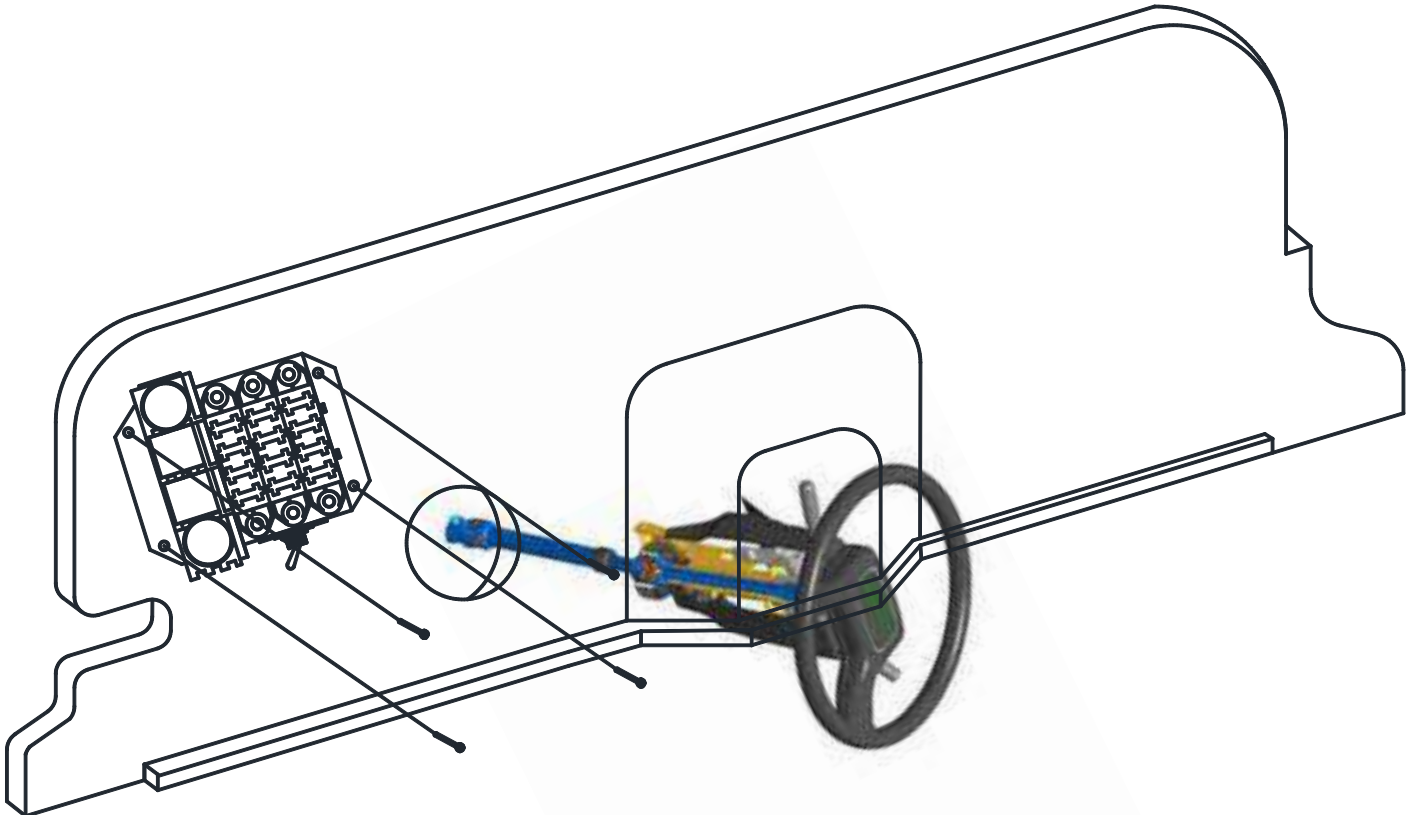

## **Standard Harness**

**Fasten mounting plate using hardware (not included) of your choice to mount snugly to firewall as shown above.**

## **Budget Harness**

**Use included 4 bolts, nuts, and spacers (Part #'s **16 & 17**) to attach snugly to a fabricated mounting plate that you will attach to the fire wall as shown above. Be careful not to pinch any wires between spacers and firewall while tightening bolts.**

\*Fuse panel pictured is our standard kit

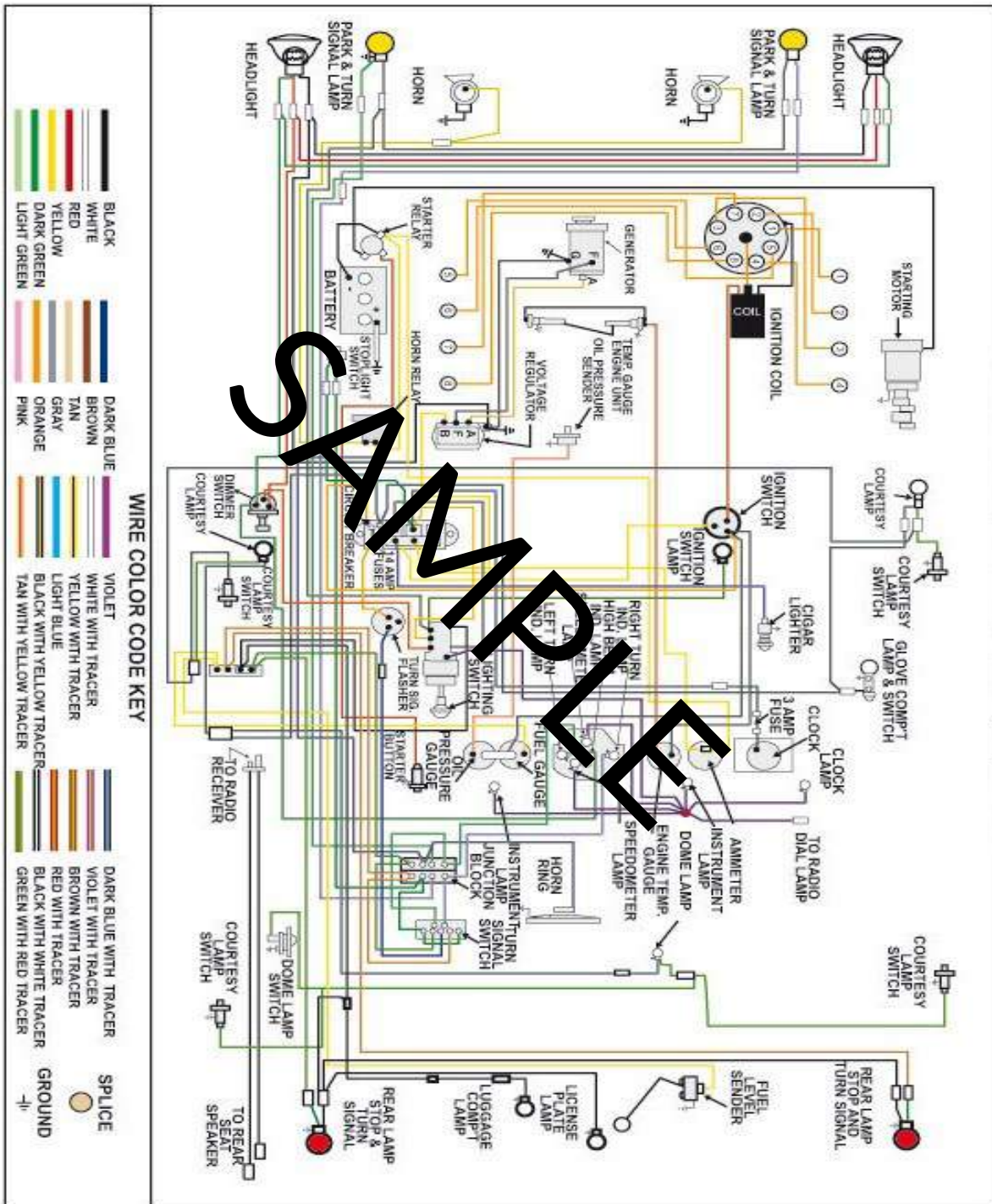

Factory wiring diagrams are available for an extra cost and are in color and laminated. Order via [KwikWire.com](http://KwikWire.com) for correct year, make, and model selection.  
 11" x 17" \$30                      18" x 24" \$40

Note: The diagrams are year, make, and model specific and are used for your vehicle wire identification and Kwik Wire cross referencing purposes. They do not include Kwik Wire specific information of which is already included in this manual.

# Motor Group

## #14 White 16 Ga. (Alternator Exciter)

Originates from the fuse panel and connects to the alternator.

**\*4 GAUGE JUMPER REQUIRED FROM STARTER SOLENOID BATTERY POST TO ALTERNATOR BATTERY POST (NOT INCLUDED IN KIT)\***

## #16 Red 10 Ga. (Starter Battery Lug)

Originates from the fuse panel and connects to the starter battery lug.

**\*\*50A Maxi Fuse (Standard Kits Only)**

Budg. kits have fusible link

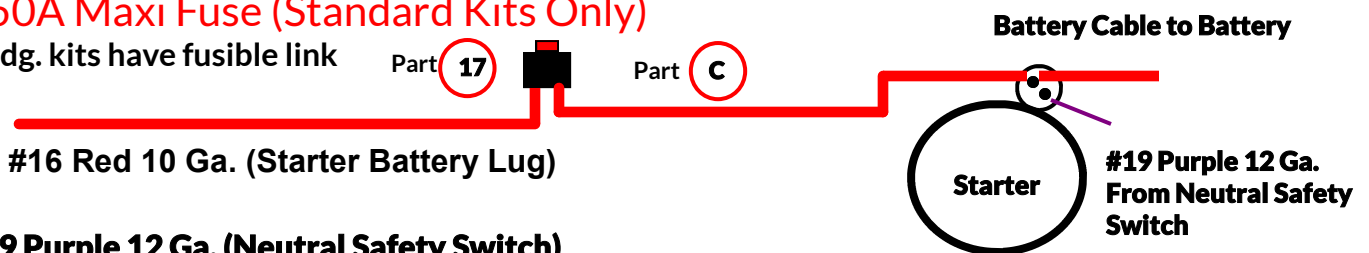

## #19 Purple 12 Ga. (Neutral Safety Switch)

1) #19 purple originates from the ignition switch and connects to the neutral safety switch (cut wire here).

2) Remaining length of #19 purple runs from other side of neutral safety switch and connects to the start lug on the starter. See Motor Group Wiring Diagram on page 12.

# 56 Green 18 Ga (Back-Up lights) and # 58 Lt Green 18 Ga (Back—Up Light Switch Power) will often be integrated as 2 of 4 terminals on a Neutral Safety Switch (I.E. Fords)

## #20 Pink 14 Ga. (+ Side of Coil or HEI)

Originates from the fuse panel and connects to the positive side of the coil.

\*When HEI distributor is used the ignition resistor is not used and the #20 + side of coil is connected to the distributor B+. Not normally used.\*

**Fuel Injection systems will use # 20 since it is HOT in RUN and START positions.**

**\*\* Switch on the side of the fuse panel will shut off power to the coil \*\***

## #21 Green 18 Ga. (Temperature Sender)

Originates from the temp gauge and connects to the temperature sending unit.

## #22 Light Blue 18 Ga. (Oil Pressure Sender)

Originates from the oil gauge and connects to the oil pressure sending unit.

## #23 Purple 18 Ga. (Tachometer)

Originates from the tachometer gauge and connects to negative side of the coil.

## #54 Red 18 Ga. (Electric Choke)

Originates from the fuse panel and connects to the positive side of the electric choke.

**\*\*Included in 20 and 22 Circuit Kits Only\*\***

## #2 Black 14 Ga. (A/C Compressor)

Originates from the heater fan switch battery negative and connects to the A/C compressor.

# Motor Group Wiring Diagram

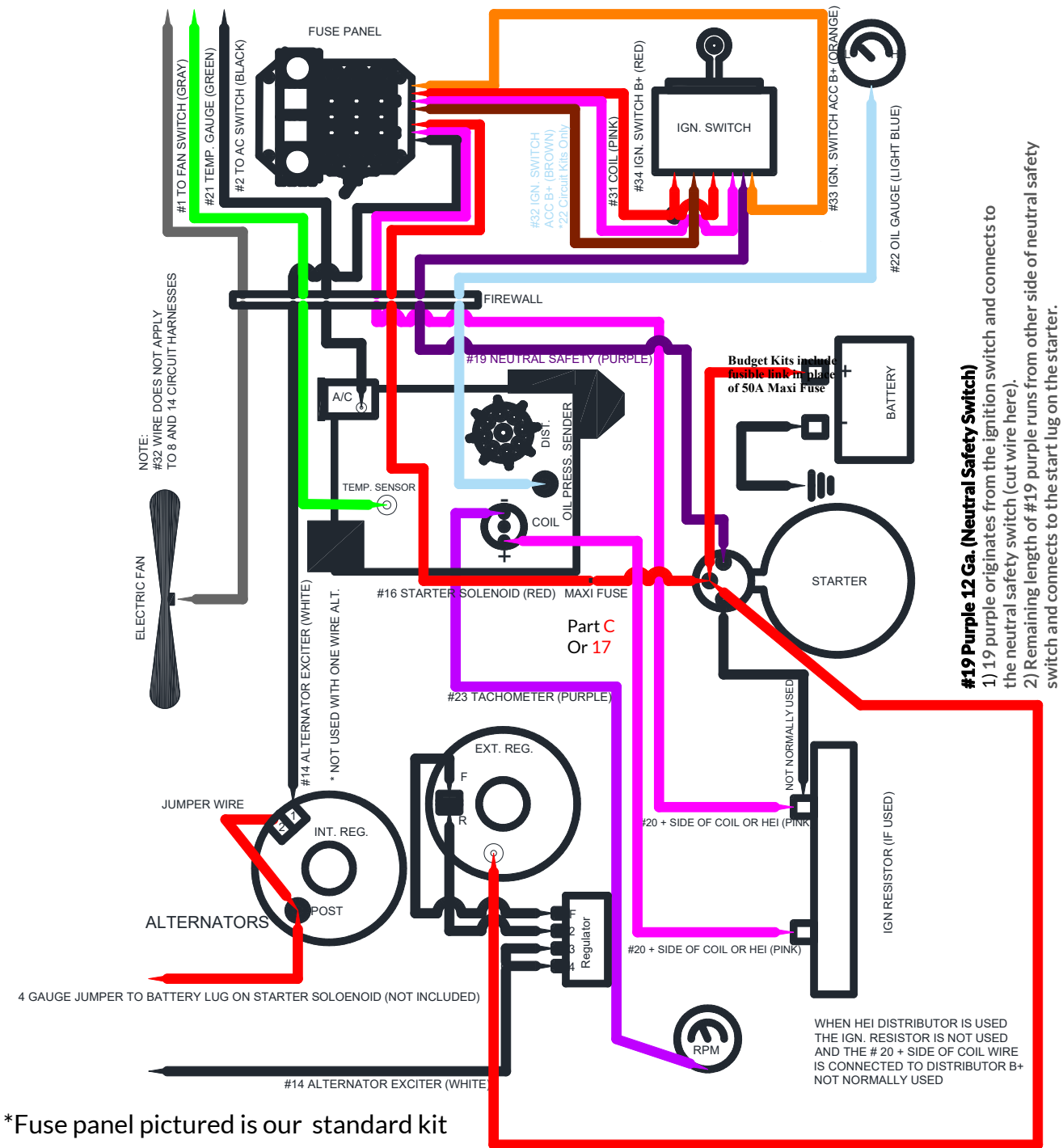

\*Fuse panel pictured is our standard kit

AMMETER GAUGE

Cut # 16 Starter Battery Lug (Red—From fuse panel) to length to run to ammeter gauge and use remaining wire to continue circuit from gauge to starter.

● = Splice

4 GAUGE JUMPER TO BATTERY LUG ON STARTER SOLOENOID (NOT INCLUDED)

**4 GA. ALTERNATOR TO STARTER JUMPER REQUIRED FOR HIGH OUTPUT ALTERNATOR**

# G.M. Charging Systems

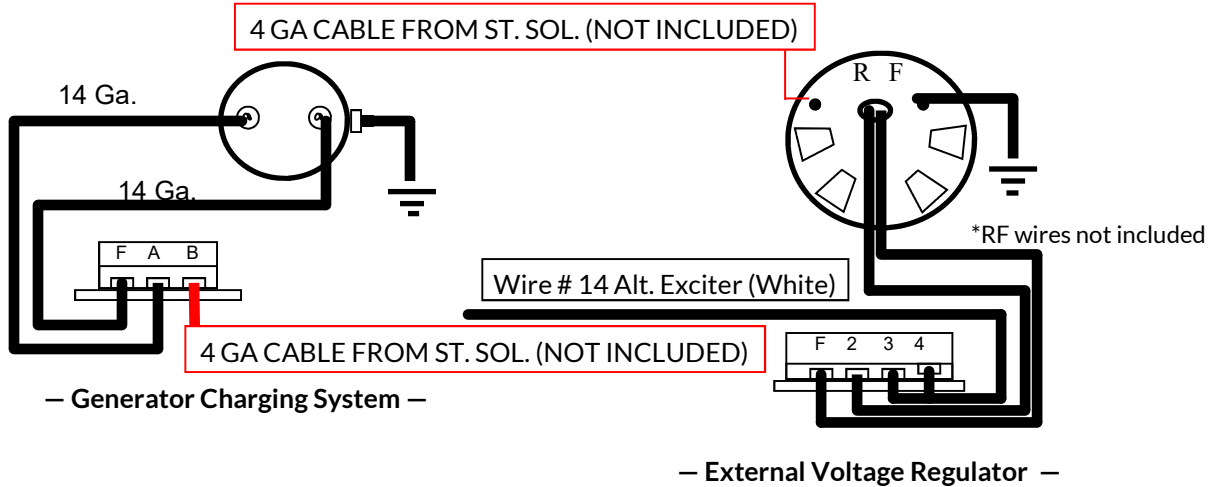

## CS-130 Alternator

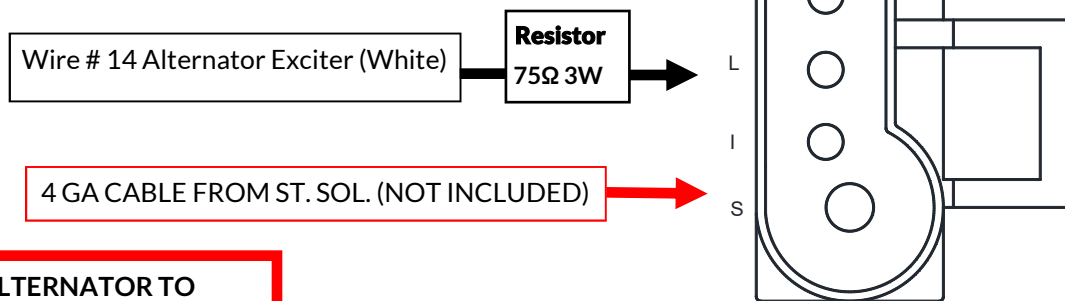

4 GA. ALTERNATOR TO STARTER JUMPER REQUIRED FOR HIGH OUTPUT ALTERNATOR

**NOTE:**  
**CANNOT BE ON THE SAME CIRCUIT WITH THE COIL OR THE ALTERNATOR WILL BACKFEED POWER TO THE COIL CAUSING THE ENGINE TO NOT SHUT OFF.**

Wire side view

## CS-130D Alternator—2 Splice Option

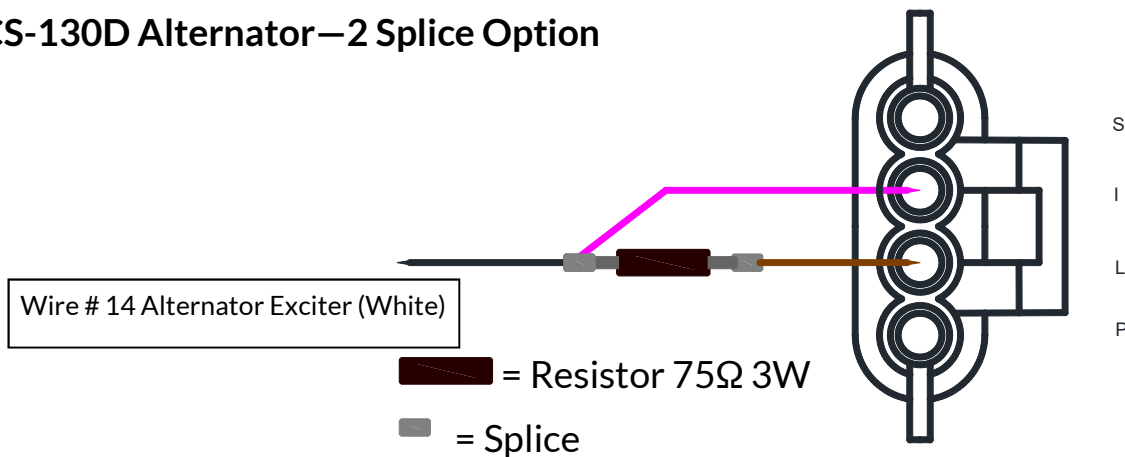

Please Note: Some foreign or inexpensively made alternators may not have diodes in them and will cause ignition/starting issues.

### CS-130D Alternator—3 Splice Option

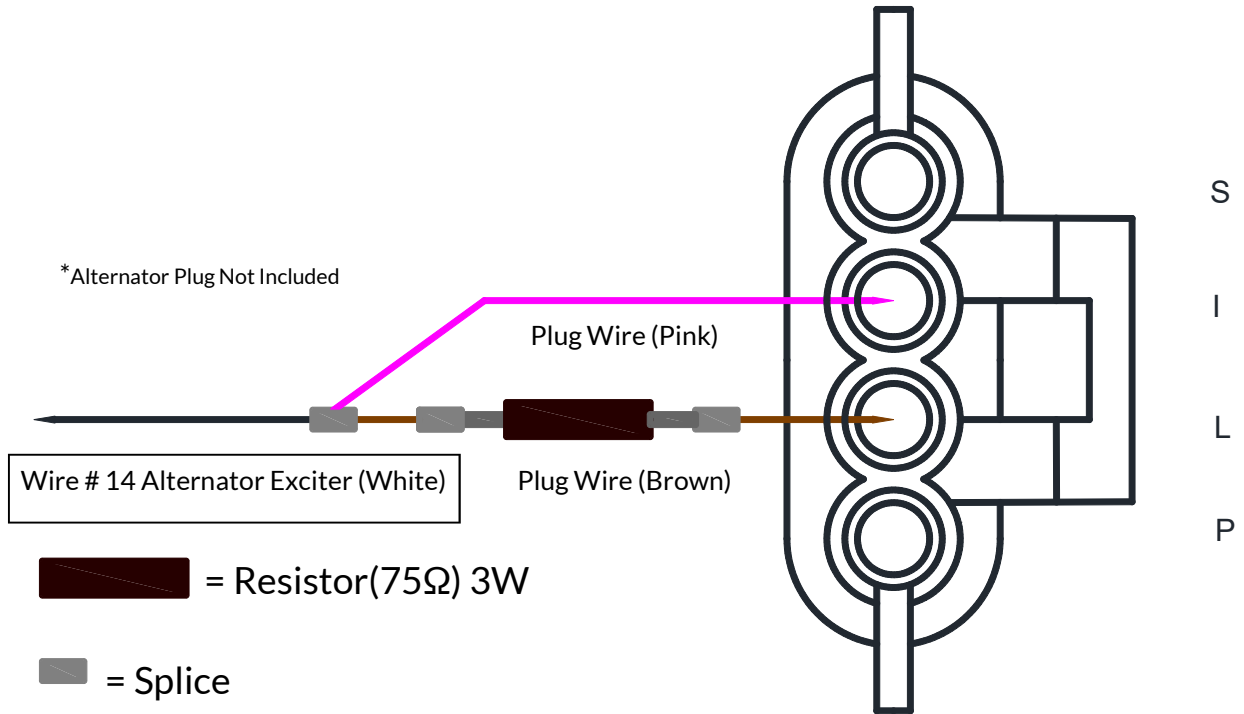

Please Note: Some foreign or inexpensively made alternators may not have diodes in them and will cause ignition/starting issues.

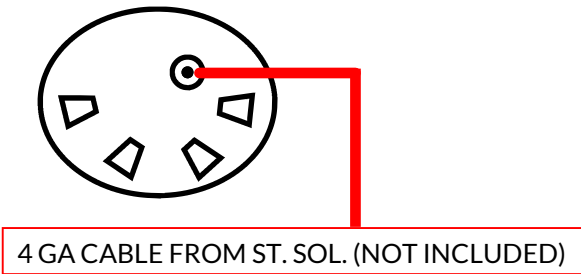

Note: Wire #14 Alt. Exciter (White) NOT USED

– 1 Wire Alternator –

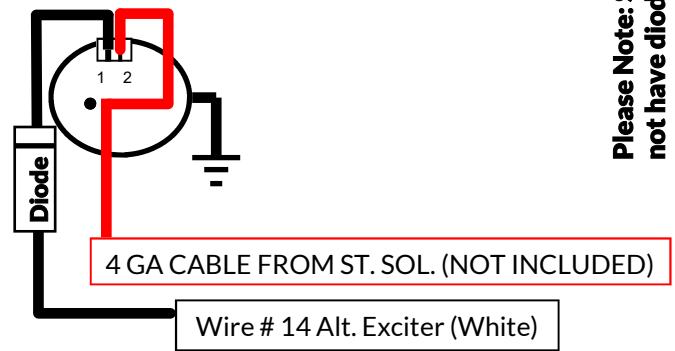

– 10 -SL Alternator –

4 GA. ALTERNATOR TO STARTER JUMPER REQUIRED FOR HIGH OUTPUT ALTERNATOR

Resistor (75Ω) 3W

# Ford Charging System

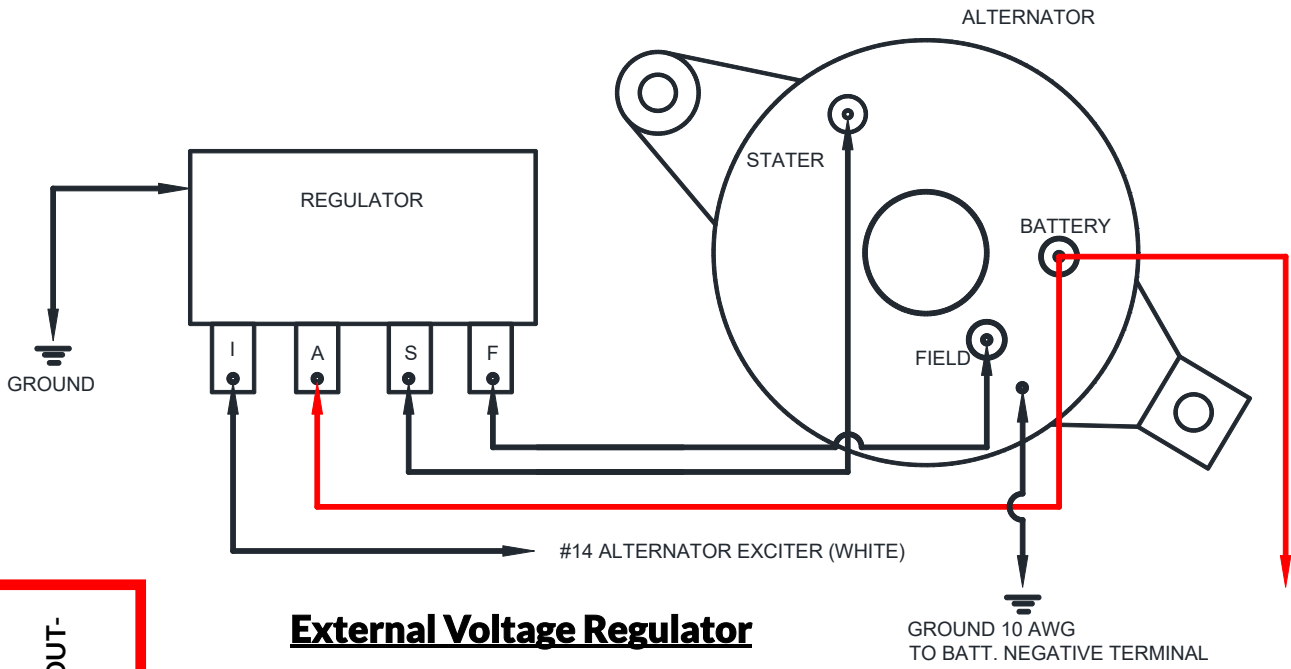

## External Voltage Regulator

4 GA. ALTERNATOR TO STARTER JUMPER REQUIRED FOR HIGH-OUTPUT ALTERNATOR

4 GAUGE CABLE FROM STARTER SOLENOID (NOT INCLUDED)

Please Note: Some foreign or inexpensively made alternators may not have diodes in them and will cause ignition/starting issues.

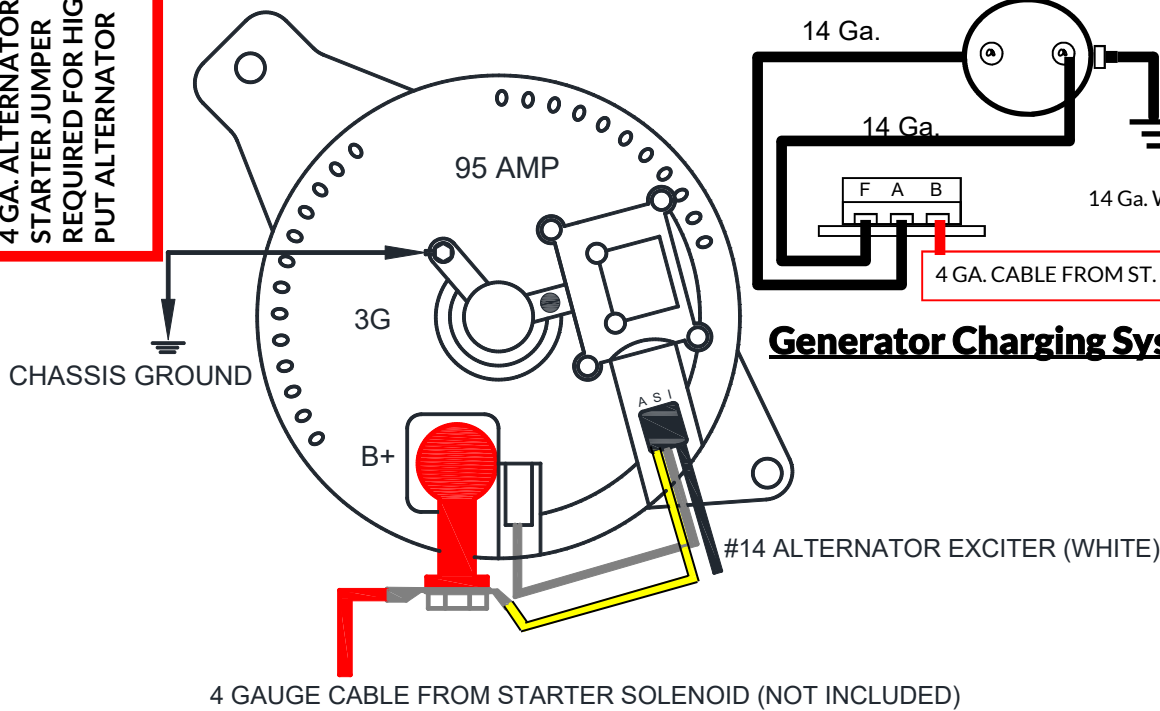

## Generator Charging System

## 3G Alternator - Internal Voltage Regulator



# Chrysler Charging System

## Alternators

External Voltage Regulators

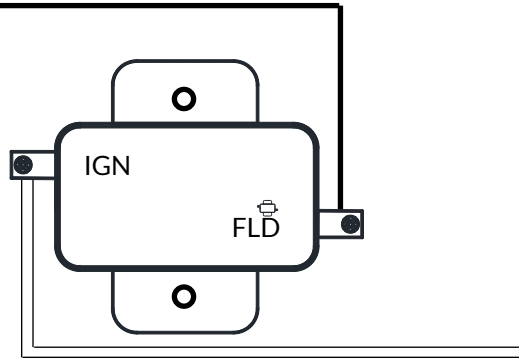
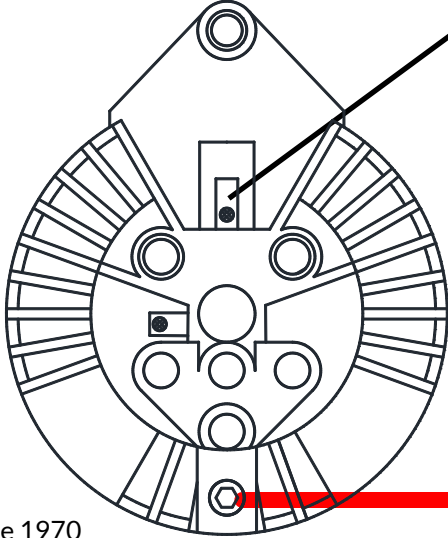

#14 Alternator Exciter (White)

4 Ga. Jumper Wire From St. Solenoid (Not Included)

4 GA. ALTERNATOR TO STARTER JUMPER REQUIRED FOR HIGH OUTPUT ALTERNATOR

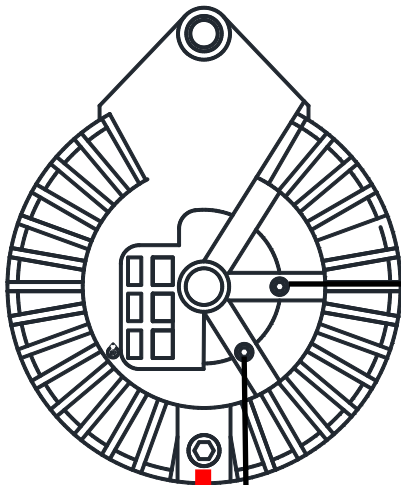

\*Field and Ignition Wires should not touch

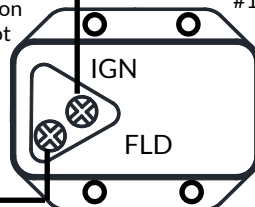

#14 Alternator Exciter (White)

#14 Alternator Exciter (White)

4 Ga. Jumper Wire From St. Solenoid (Not Included)

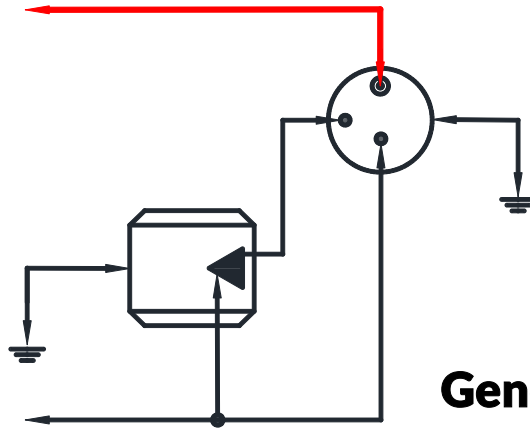

○ = Splice

Please Note: Some foreign or inexpensively made alternators may not have diodes in them and will cause ignition/starting issues.

# Ignition Group

## # 31 Pink 14 Ga. (Ignition Coil)

Originates from the fuse panel and connects to the ignition switch terminal marked "IGN."

## # 32 Brown 12 Ga. (Ignition Accessory)

Originates from the fuse panel and connects to the ignition switch terminal marked "ACC" - (22 Circuit Only).

## # 33 Orange 12 Ga. (Ignition Accessory)

Originates from the fuse panel and connects to the ignition switch terminal marked "ACC."

## # 34 Red 12 Ga. (Ignition Power)

Originates from the fuse panel and connects to the ignition switch terminal marked "BAT."

## # 19 Purple 12 Ga. (Neutral Safety Switch)

Originates from the ignition switch "ST" and connects to the neutral safety switch. Use extra wire for connection of neutral safety to starter.

### – Dash Mounted Ignition Switch – KW Universal # 70702B

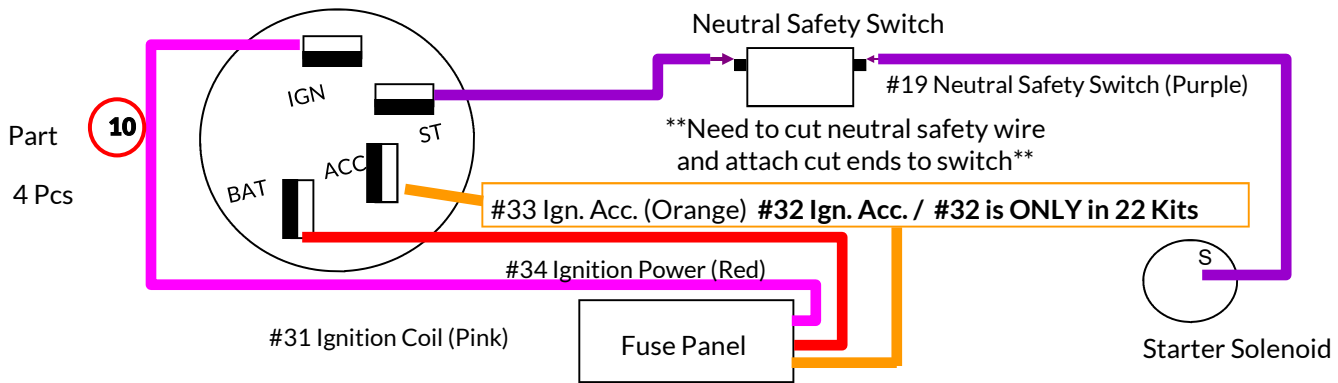

### – Key on the Column –

# 34 wire must go to both terminal blocks (Included in the bag of parts—6" red wire)

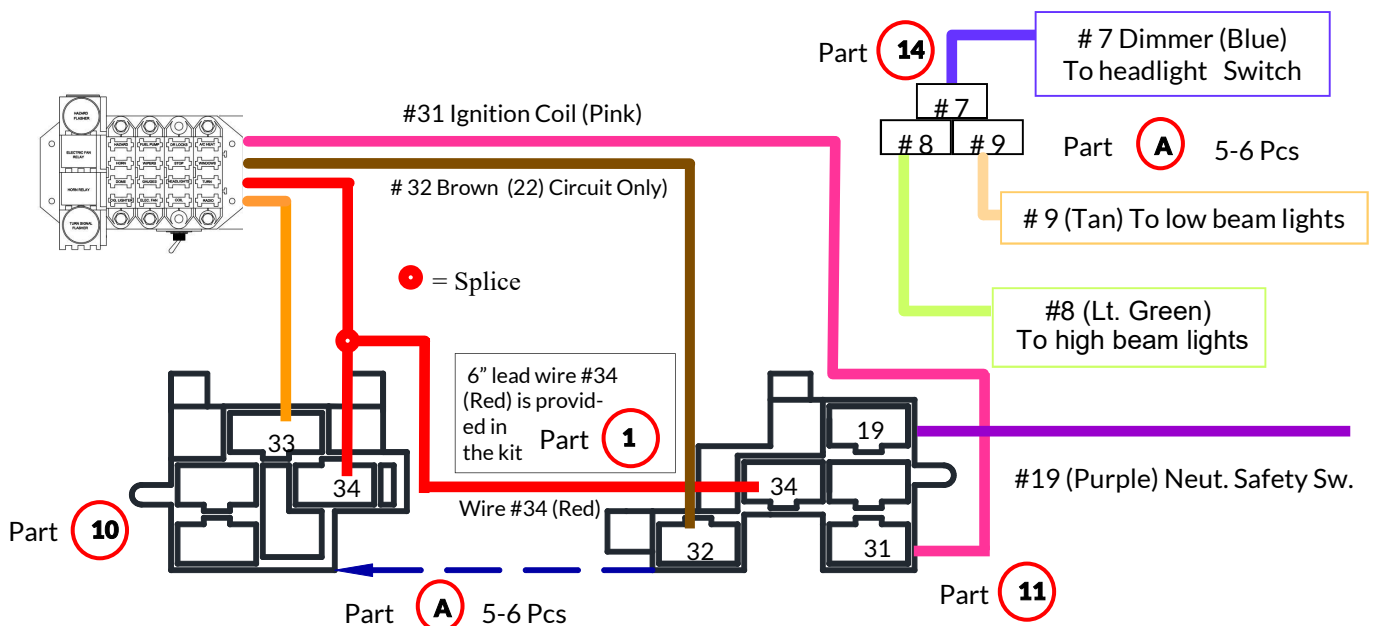

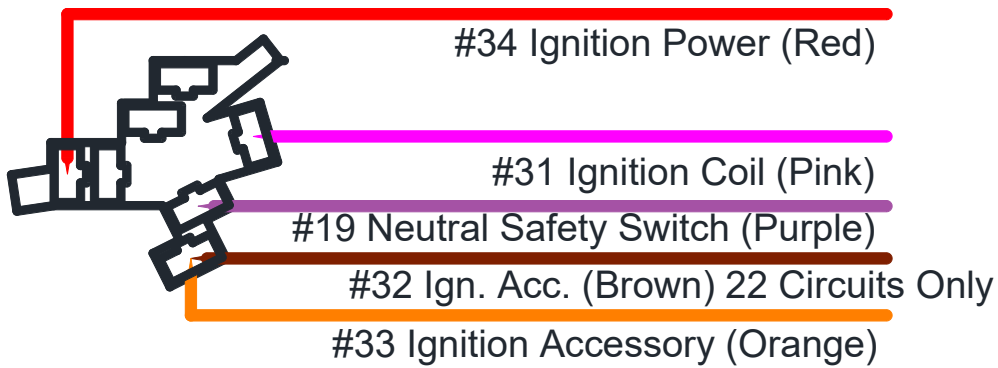

**GM Truck Dash Mount Ignition Switch**

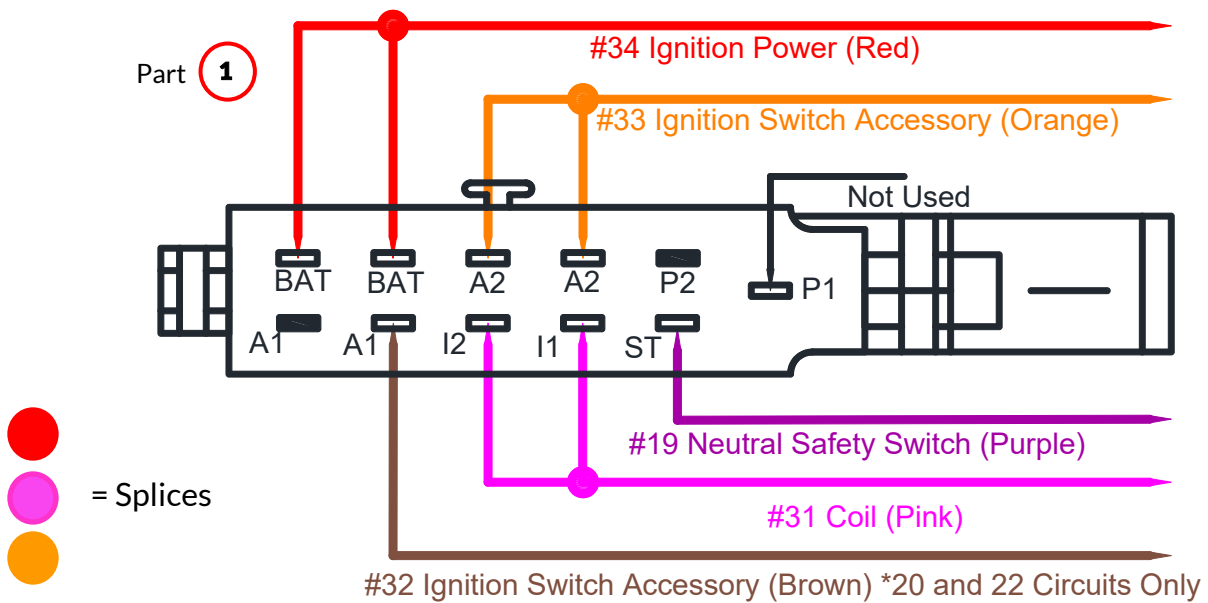
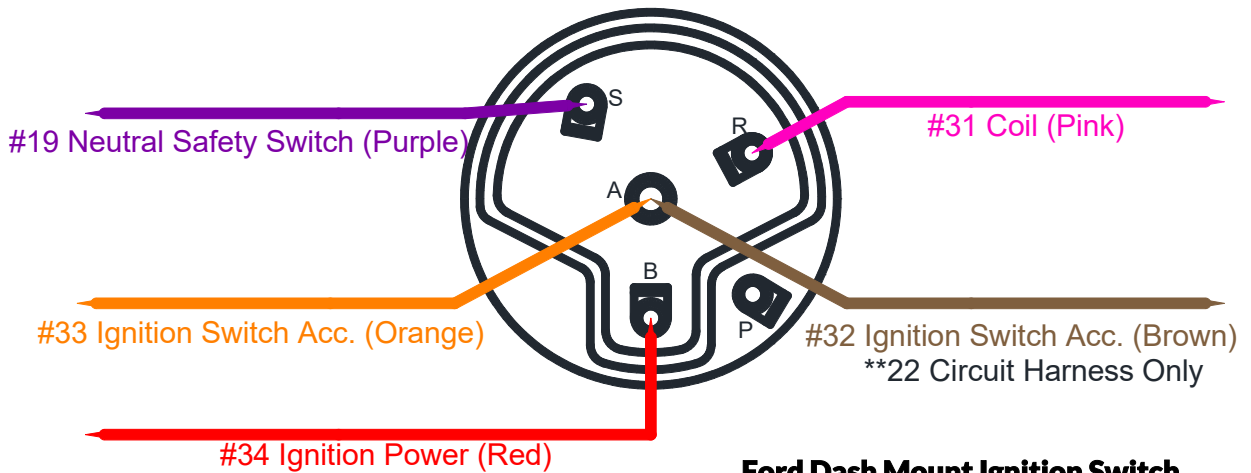

**— Mid 50's Ignition Switch —**

# Ignition Group

## – Dash Mounted Ignition Switches –

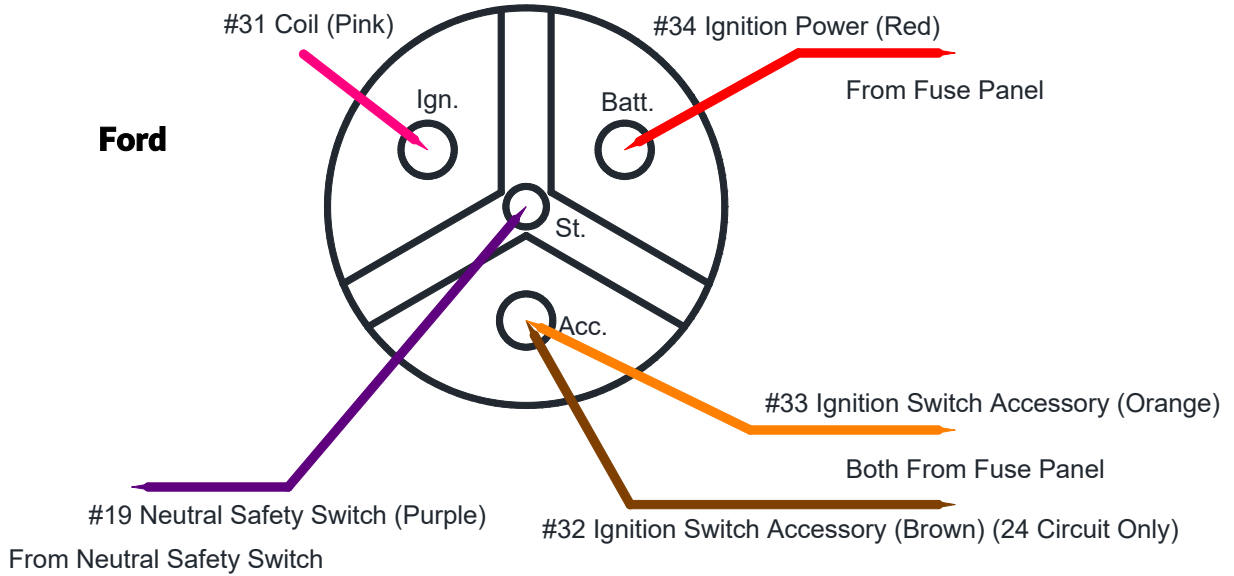

### 1955 to 1957 GM

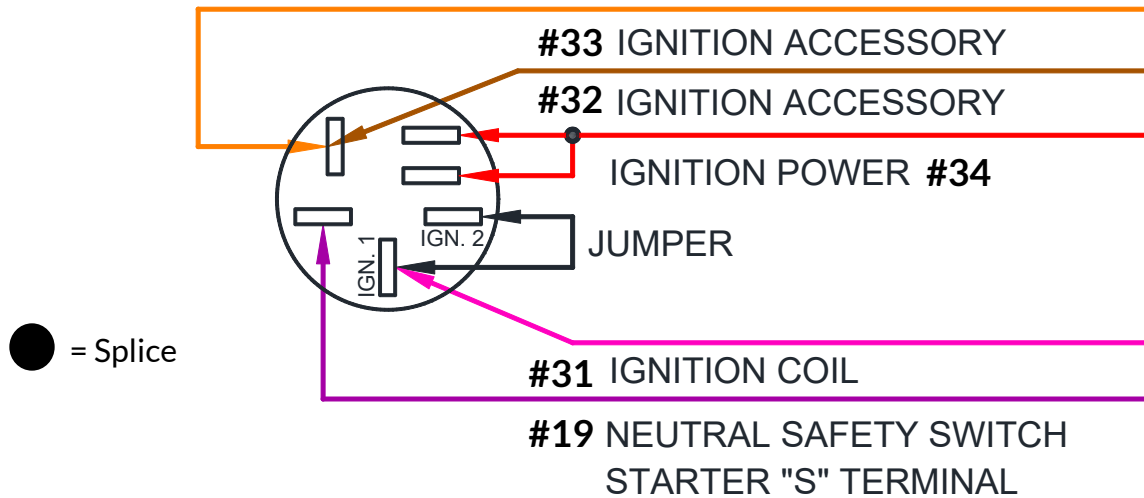

**NOTE:**

In the original '55 to '57 vehicles the harness power went out to the ignition resistor and then returned back to the ignition switch for coil output. The jumper wire shown above replaces that circuit and is required to make the ignition switch function correctly. The stock ignition switches had a high failure rate and we recommend replacing the switch if any electrical issues arise.

# HEI ON COIL CONNECTIONS

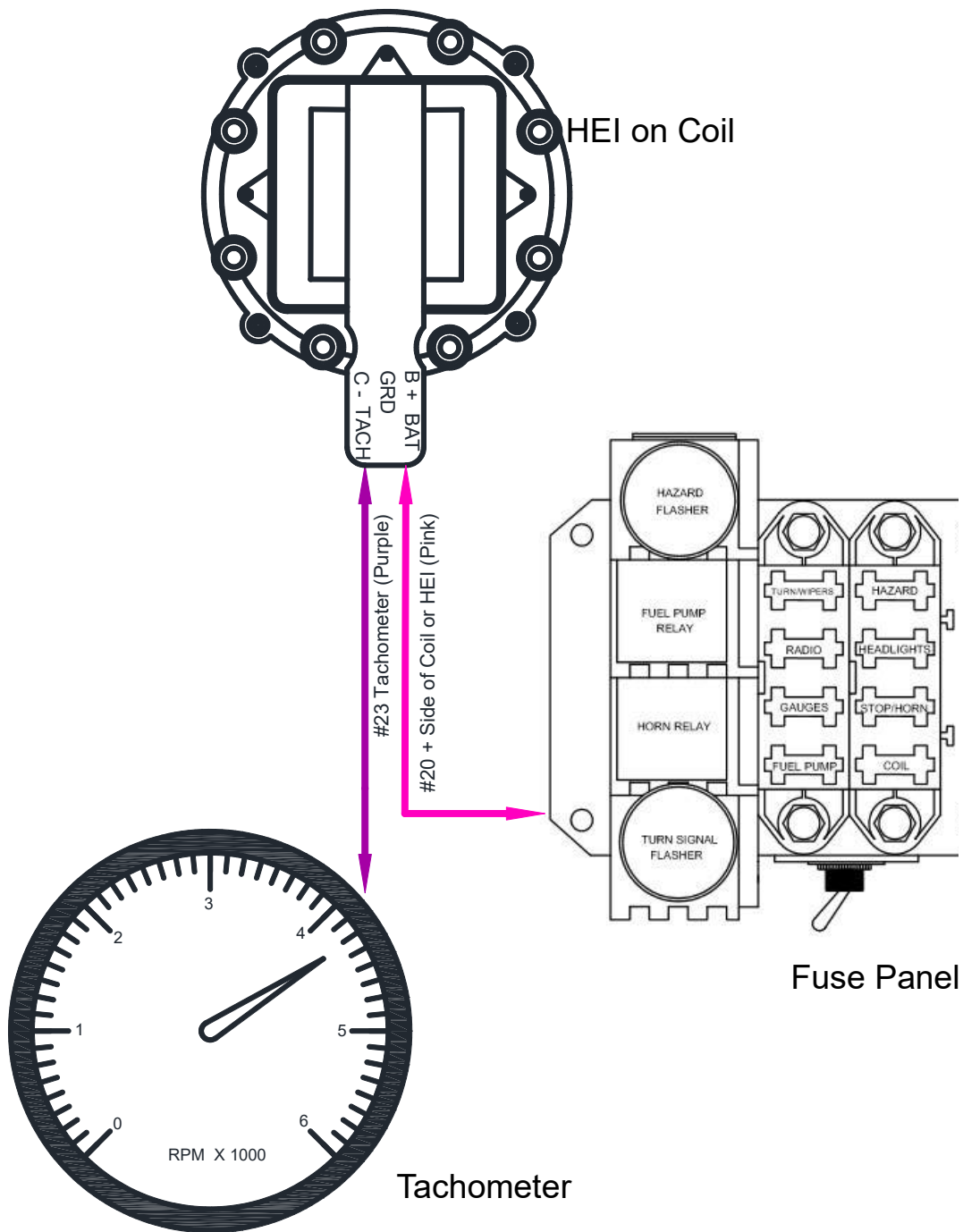

\*Fuse panel pictured is our standard kit

### – HEI Ignition Hook Up –

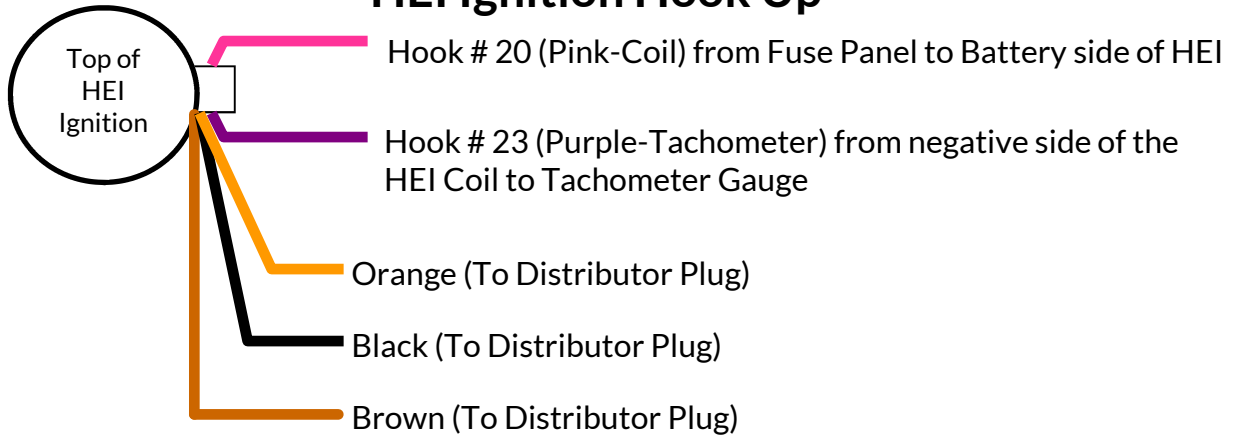

### – MSD Ignition Hook Up –

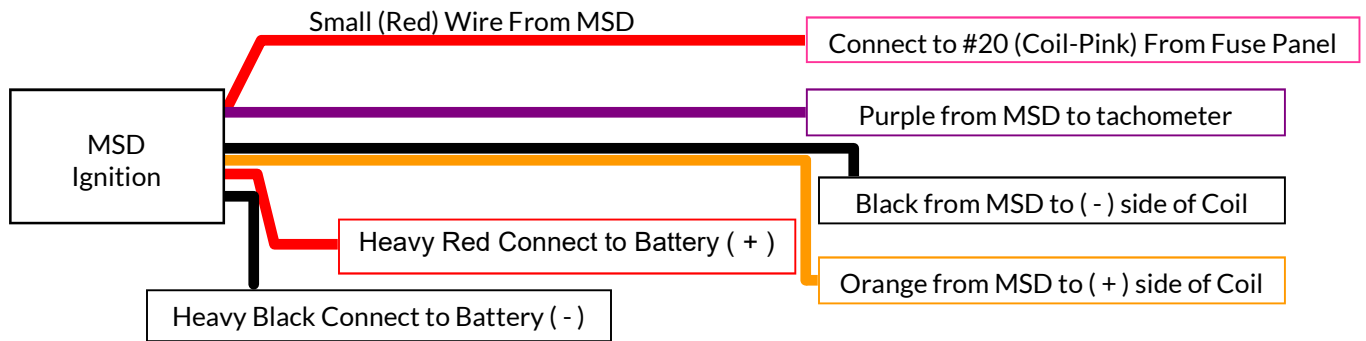

### –Coil With Ballast Hook Up –

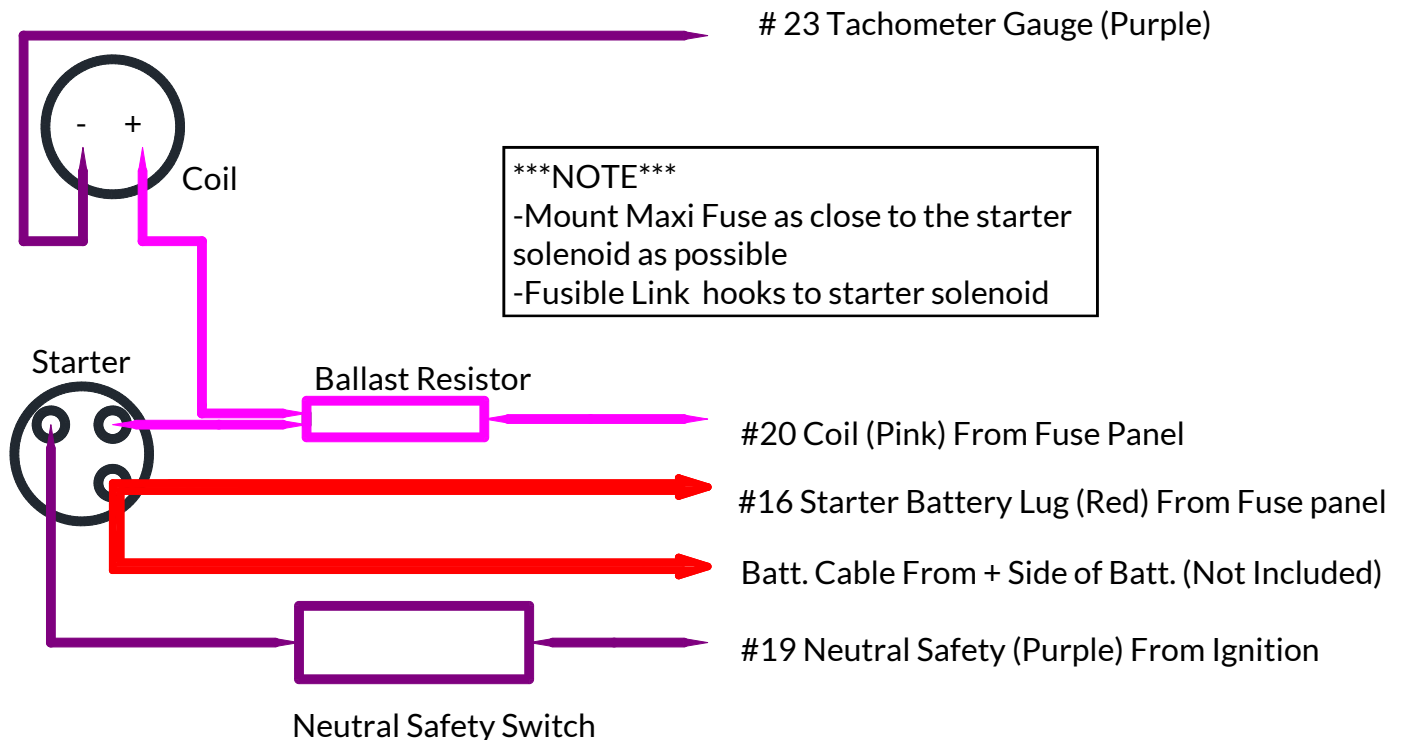

—Coil Without Ballast Hook Up —

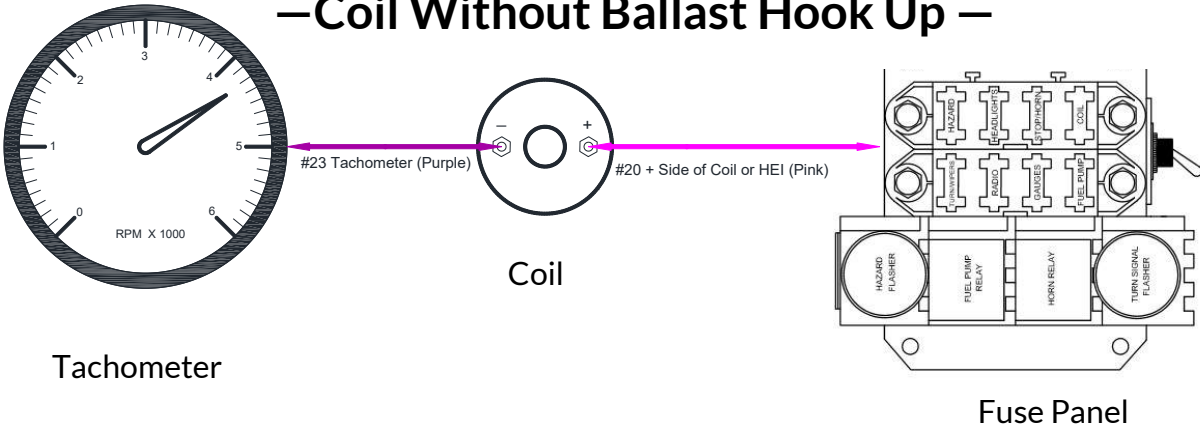

—GM Starter Connections—

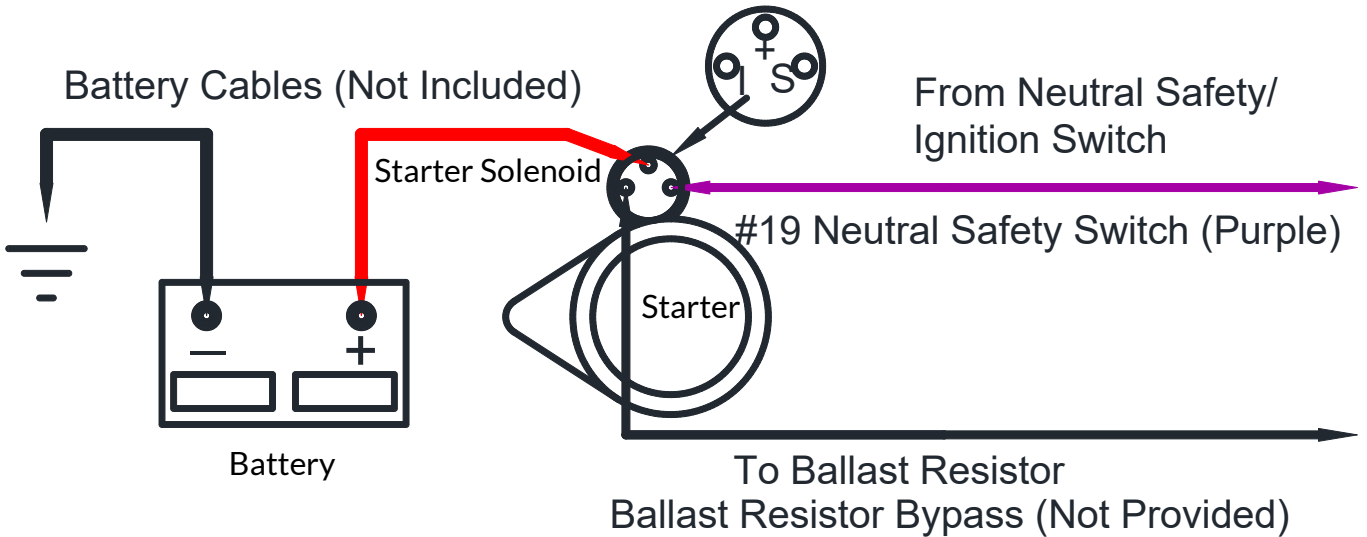

—Ford Starter Solenoid—

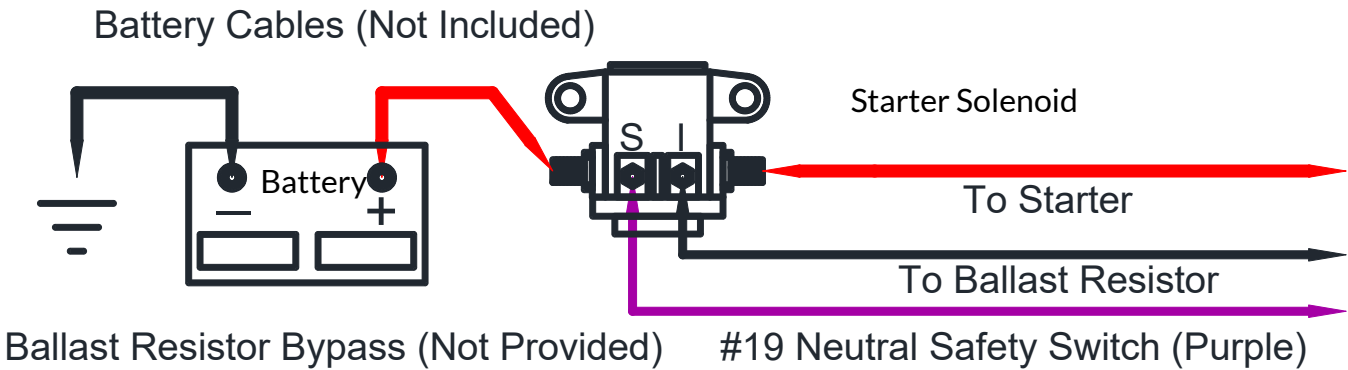



# Points Ignition

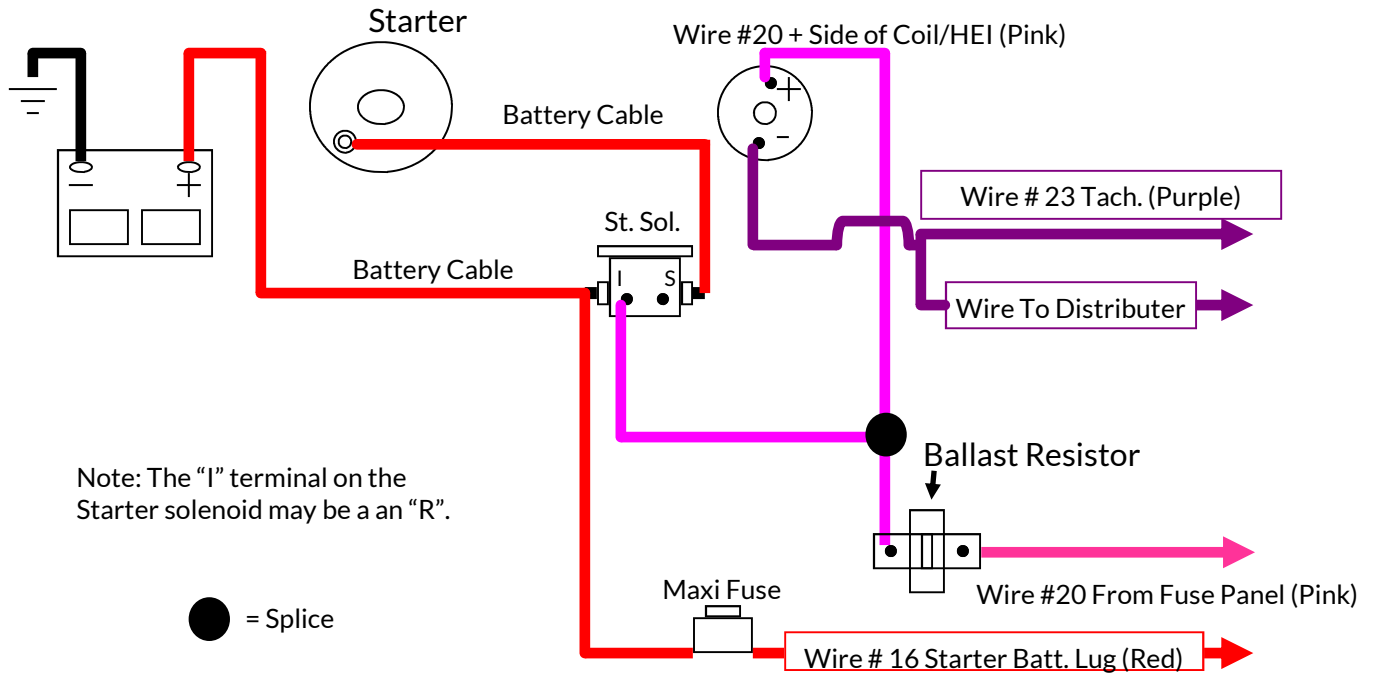

# Ignition with Duraspark II

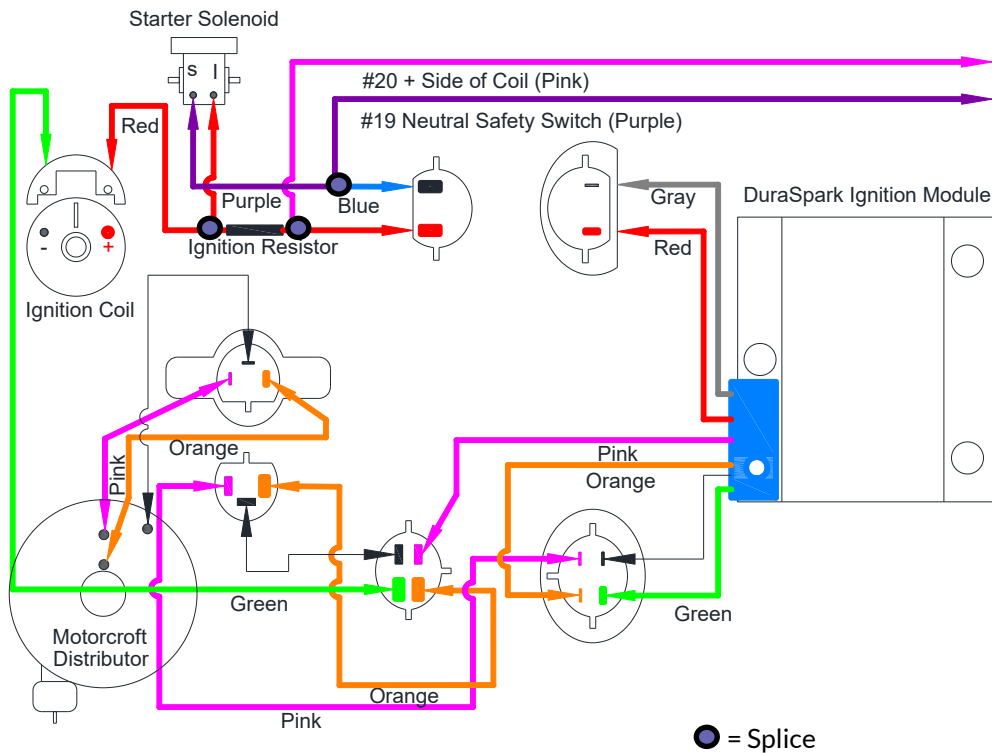

# Mopar Ignition

Battery Cables Not Included

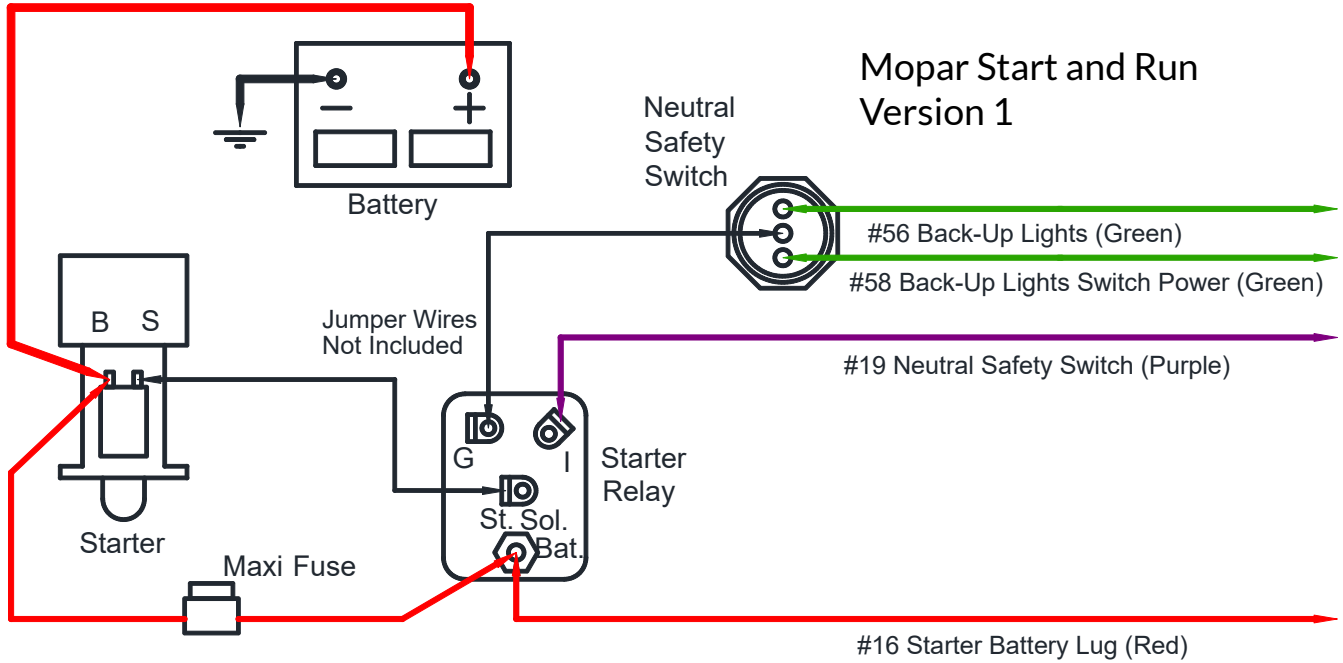

## Mopar Start and Run Version 2

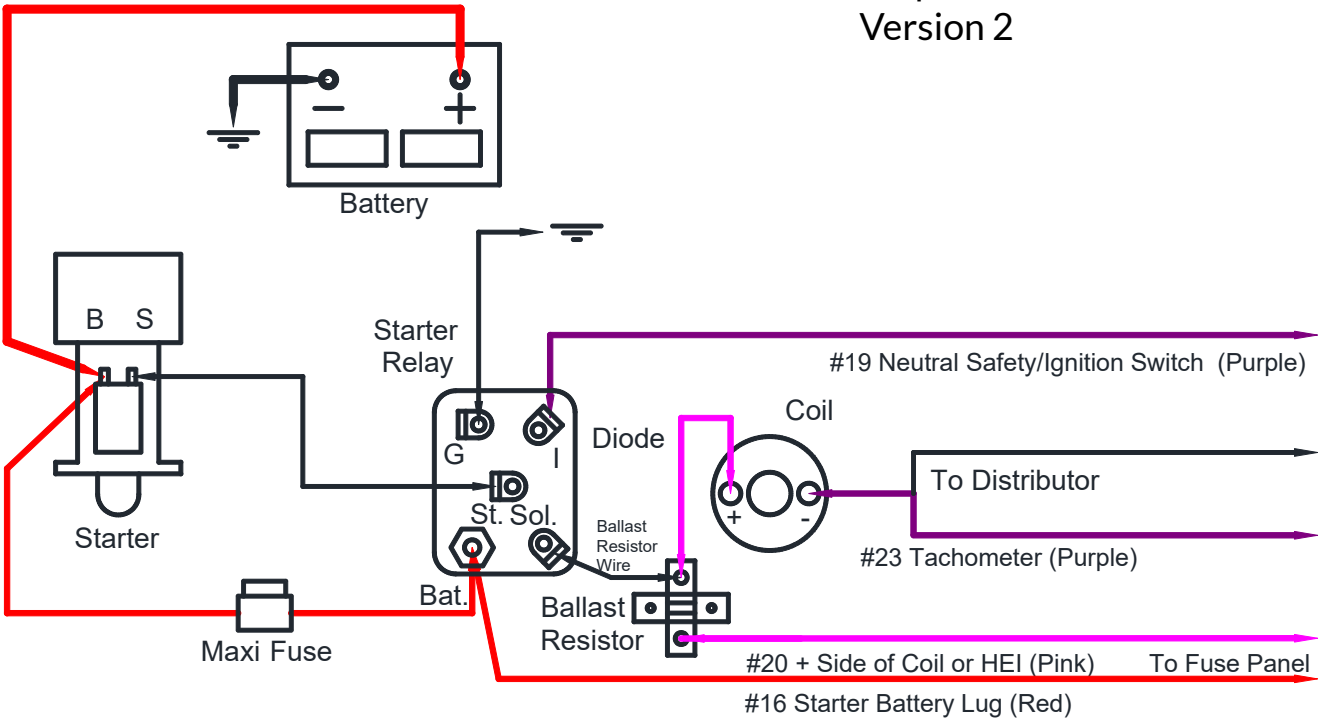

# Ignition System

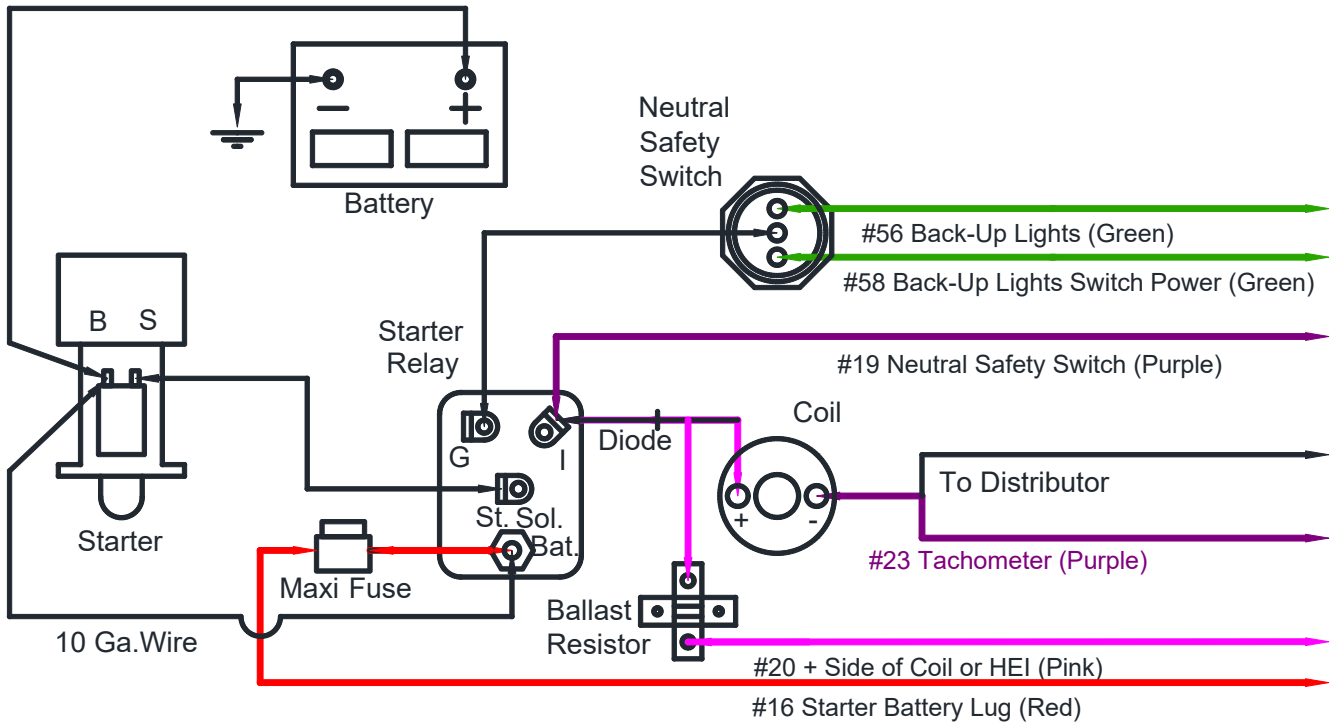

# Push Start Ignition

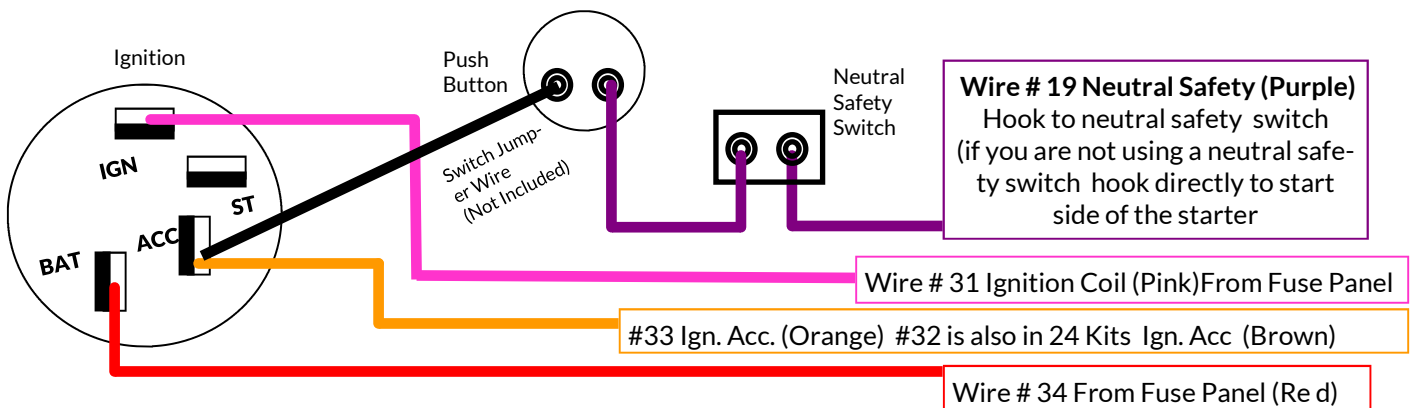

## Headlight Group H-1

**# 27 Brown 16 Ga. (Front Parking Lights)**

Originates from the headlight switch and connects to the parking lights.

**# 26 Light Blue 16 Ga. (Front Left Turn Signal)**

Originates from the turn signal plug (Position H) and connects to the front left turn signal light.

**# 25 Blue 16 Ga. (Front Right Turn Signal)**

Originates from the turn signal plug (Position J) and connects to the front right turn signal light.

**# 24 Green 14 Ga. (Horn)**

Originates from the horn relay on the fuse panel and connects to the horn speaker.

*(Relay is built into the fuse panel on all budget and standard harnesses) (Refer to page 27 for horn detail)*

**# 9 Tan 14 Ga. (Low Beam)**

Originates from the dimmer switch and connects to the left and right low beam headlights.

**# 8 Light Green 14 Ga. (High Beam)**

Originates from the dimmer switch and connects to the left and right high beam headlights.

**# 1 Gray 14 Ga. (Electric Cooling Fan)**

Originates from the accessory switch group and connects to the fan power wire.

### Headlight Plug Wiring (Rear View)

Part **B**  
2 Plugs  
6 Terminals



**4 Headlight Configuration**  
Requires only jumping #8 High Beam Light (Lt. Green) Wire and Ground on Left & Right Plugs

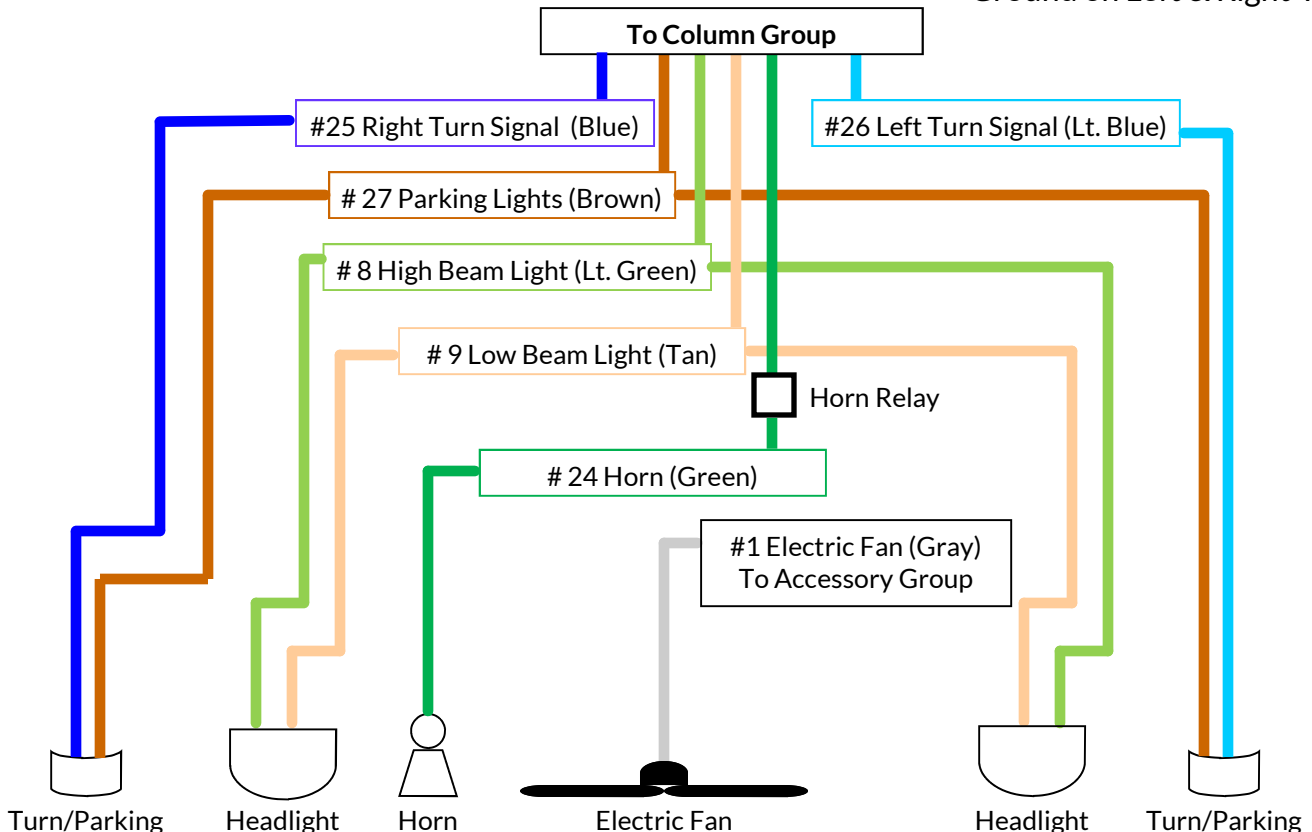

# Horn Wiring

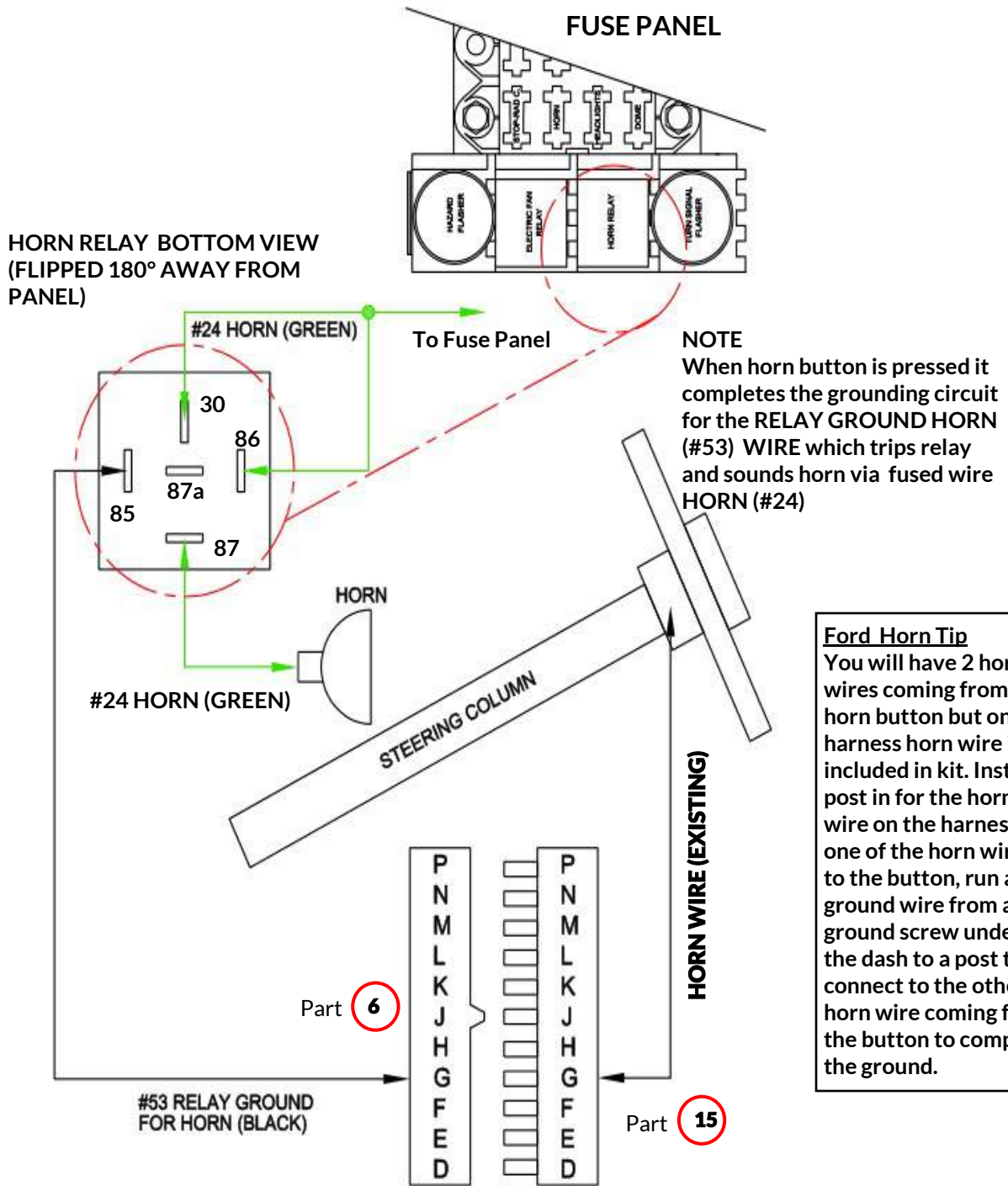

\*Fuse panel pictured is our standard kit

**MALE COLUMN CONNECTOR (EXISTING ON CAR FOR GM COLUMNS. PART 15 INCLUDED IN FORD PARTS BAG ONLY)**

# Electric Fan

## **# 1 Gray 14 Ga. (Electric Cooling Fan)**

Originates from the fan switch or relay and connects to the electric fan.

*(This wire is located in the Accessory group switches)*

**Relay is built into the system on Standard 14, 20, and 22 circuit harnesses only.**

Connect wire #1 electric fan to power lead on fan.

## **# 6 Gray 14 Ga. (Cooling Fan Switch Power) - WIRE IS IN BUDGET KITS ONLY**

Originates from the fuse panel and powers the trigger wire on the electric fan relay

*(This wire is located in the Accessory switches group Battery Positive)*

**Relay is built into the system on Standard harnesses only** this wire is connected in the fuse panel from the factory.

## **# 62 Black 14 Ga. (Relay Ground or Thermostat)**

**Relay is built into the system on 14, 20, and 22 circuit STANDARD harnesses only.**

Connect this wire to a toggle switch for manual operation or connect to the thermostat switch.

## **\*\*Electric Fan Relay Kit can be purchased for 8 circuit as an add on:\*\***

Kwik Wire Pre-wired Relay Kit Part # 2078

Kwik Wire Relay Kit Part # 6060

Kwik Wire Thermostat Switch Part # 2079

Kwik Wire Adjustable Thermostat switch Part # 50801

### **– Electric Fan Relay –**

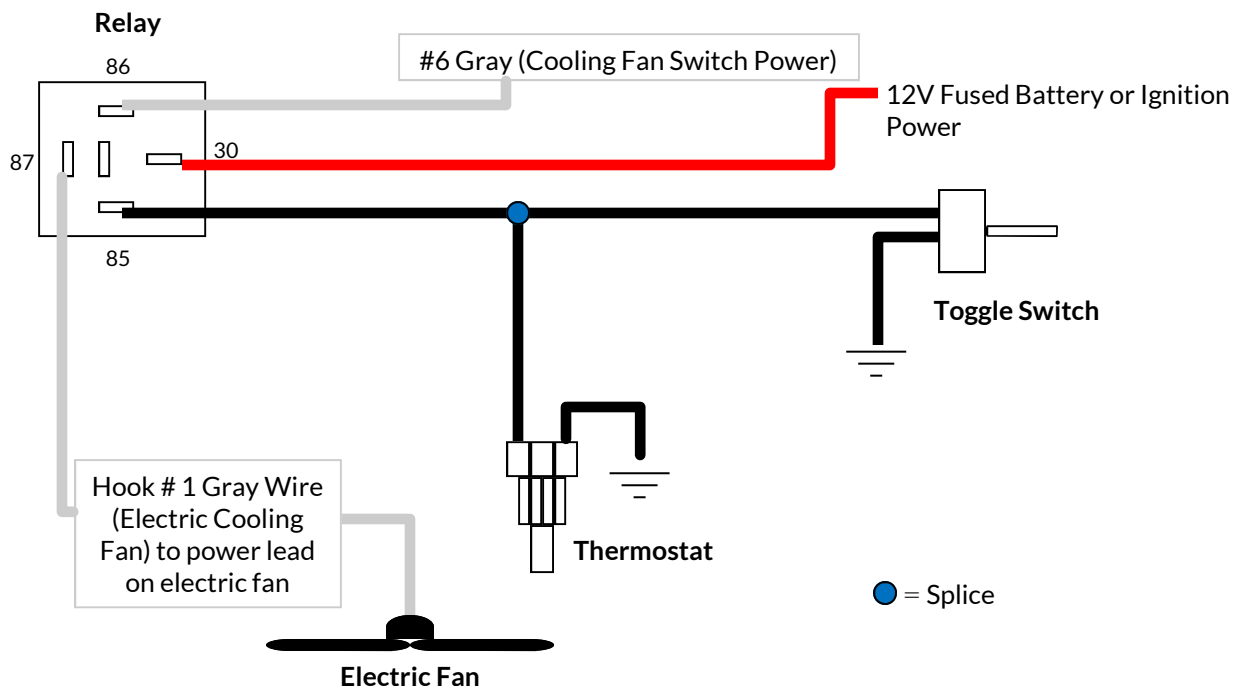

# Dome Light

## # 45 White 16 Ga. (Dome Light Power)

Originates from the fuse panel and hooks to the positive side of all interior lighting. Run a ground wire on the negative side of all interior lighting to all door jam switches as well as the headlight switch.

**\*\*All door jam switches and headlight switch must be grounded\*\***

**#45 Wire Not Used in Ford D1 and D2 Style switch**

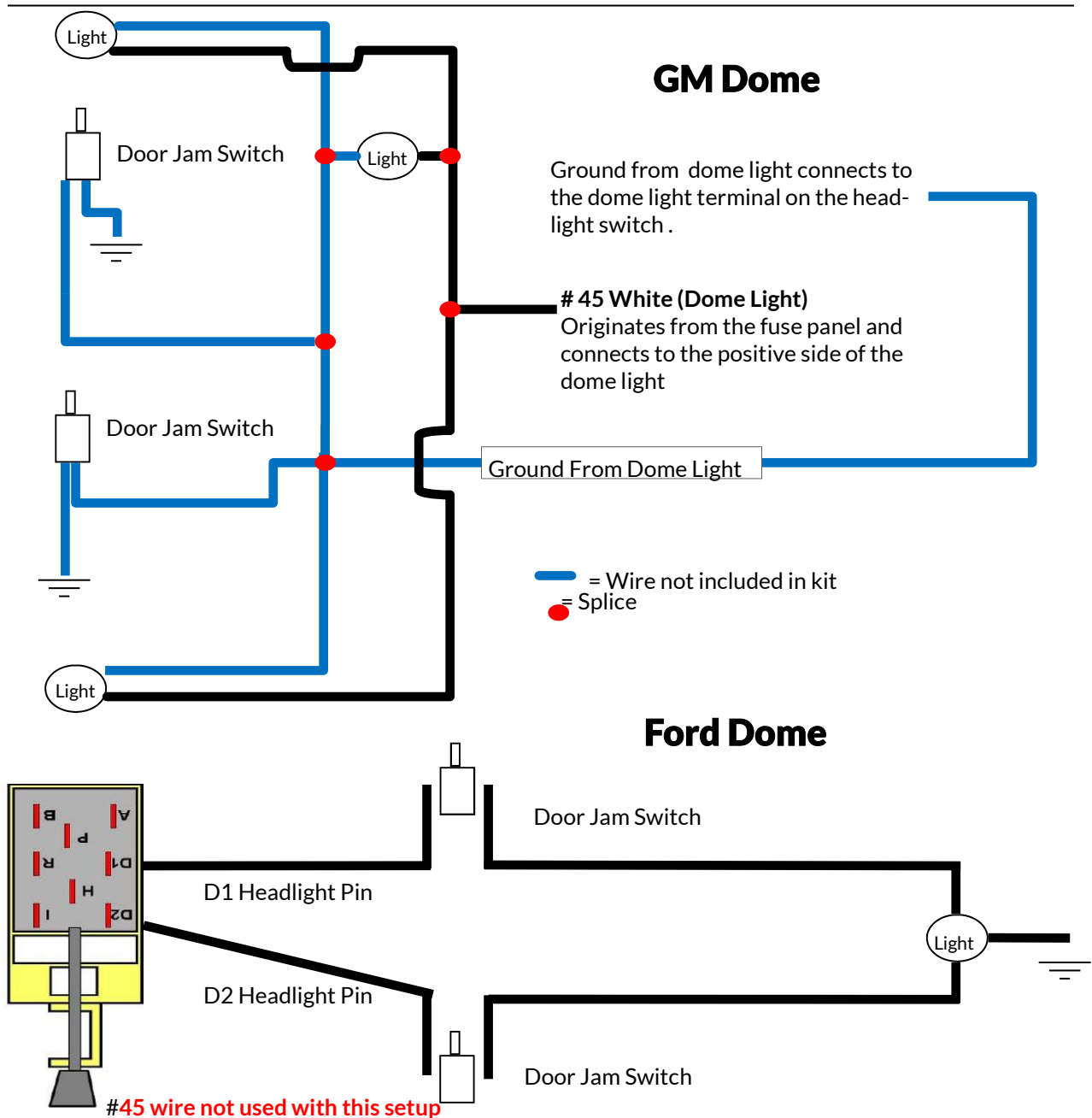



# Accessory Group & Battery Positive

## — Accessory Switch Group —

### # 2 Black 14 Ga. (A/C Compressor)

Connect to thermostat switch power.

### # 1 Gray 14 Ga. (Electric Cooling Fan)

Originates from the relay or switch and connects to electric fan power lead.

## — Accessory Group Battery Positive —

### # 3 Tan 14 Ga. (Cigarette Lighter Power)

Originates from the fuse panel and connects to cigarette lighter battery positive terminal on the back of the lighter. This circuit is included in 20 and 22 circuit harnesses only.

### # 4 Black 14 Ga. (A/C—Heat Switch Power)

Originates from the fuse panel and connects to the heater fan switch battery positive.

### # 5 Blue 16 Ga. (Wiper Switch Power)

Originates from the fuse panel and connects to windshield wiper switch battery terminal.

## GM Wiper

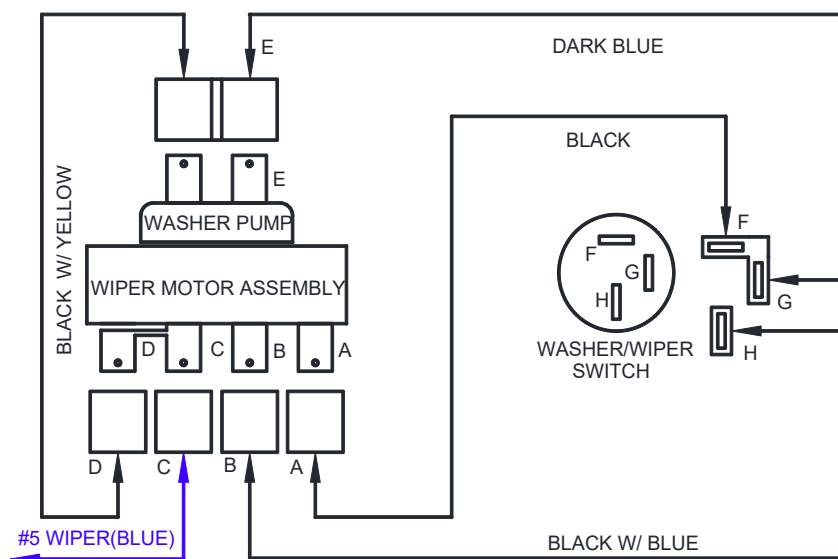

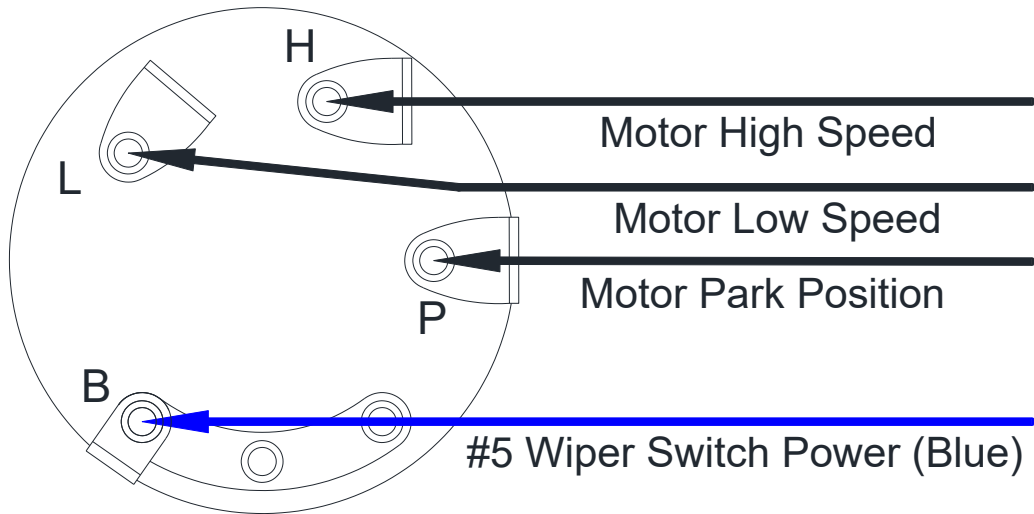

**KW – 9902 Wiper Switch**

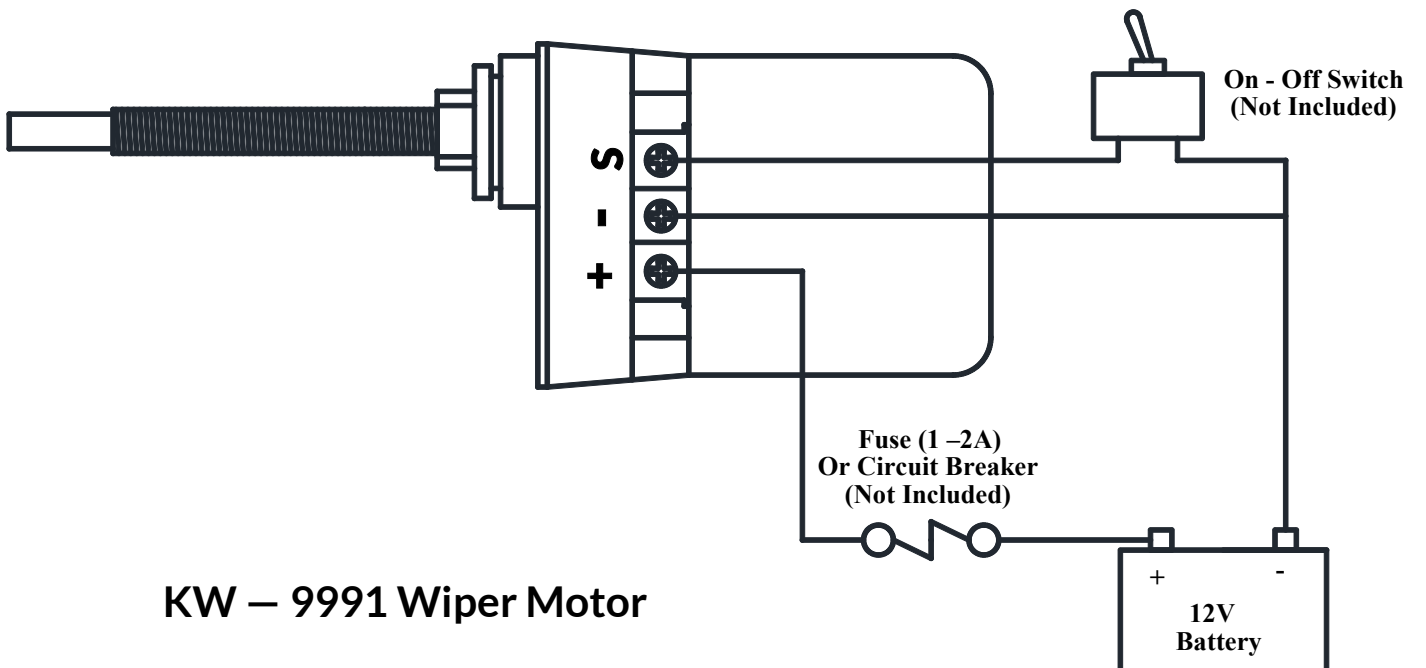

**KW – 9991 Wiper Motor**

## Ford Wiper Switch

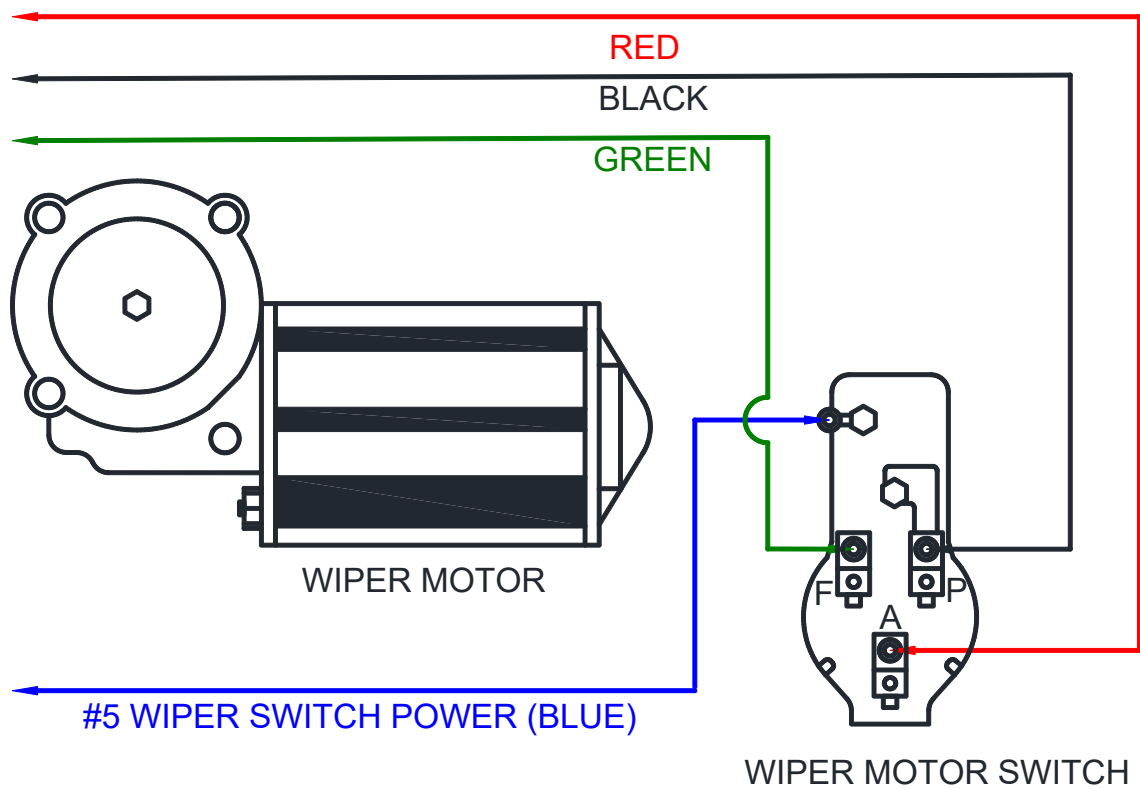

## Chrysler Wiper Switch

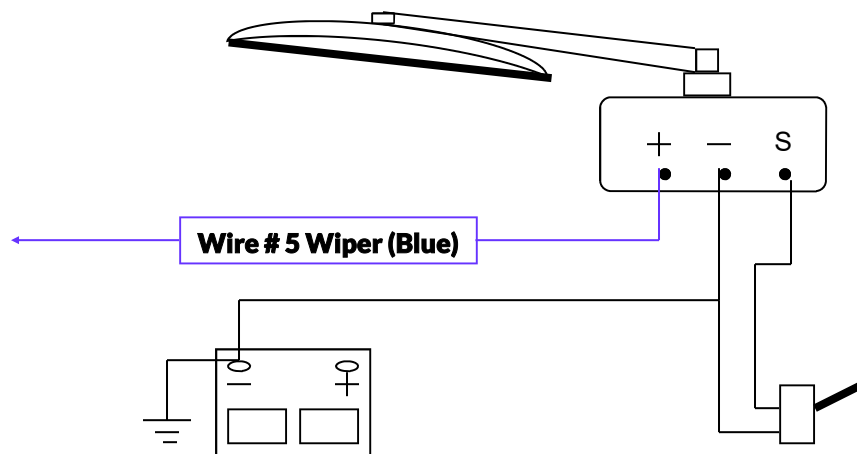

# Instrument Group

**# 35 Red 16 Ga. (Power for Gauges)**

Originates from the fuse panel and connects to the positive side of each gauge.

**# 30 Red 14 Ga. (Power for Gauge Lights)**

Originates from the headlight switch and connects to the positive side of all dash lights.

**# 21 Green 18 Ga. (Temperature Sender)**

Originates from the temp gauge and connects to the temperature sending unit.

**# 22 Light Blue 18 Ga. (Oil Pressure Sender)**

Originates from the oil gauge and connects to the oil pressure sending unit.

**# 23 Purple 18 Ga. (Tachometer)**

Originates from the tachometer gauge and connects to the negative side of the coil.

**# 53 Black 18 Ga. (Relay Ground for Horn)**

Originates from the relay on fuse panel and connects through column plug position "G" to the horn button surround (Do not ground at another location. See page 27 for details)

**# 36 Green 18 Ga. (High Beam Indicator)**

Originates from the High Beam wire # 8 and connects to the high beam indicator light.

**# 37 Light Blue 18 Ga. (Left Turn Indicator)**

Originates from the Column Group and connects to the left turn indicator light on the dash.

**# 38 Blue 18 Ga. (Right Turn Indicator)**

Originates from the Column Group and connects to the right turn indicator light on the dash.

**# 39 Pink 16 Ga. (Fuel Sending Unit)**

Originates from the fuel sender and connects to the fuel gauge "S" terminal.

**"Be sure to ground all gauges to a clean ground\*\*"**

**Instrument Group Wiring Diagram on Page 34**

# Instrument Group Wiring Diagram

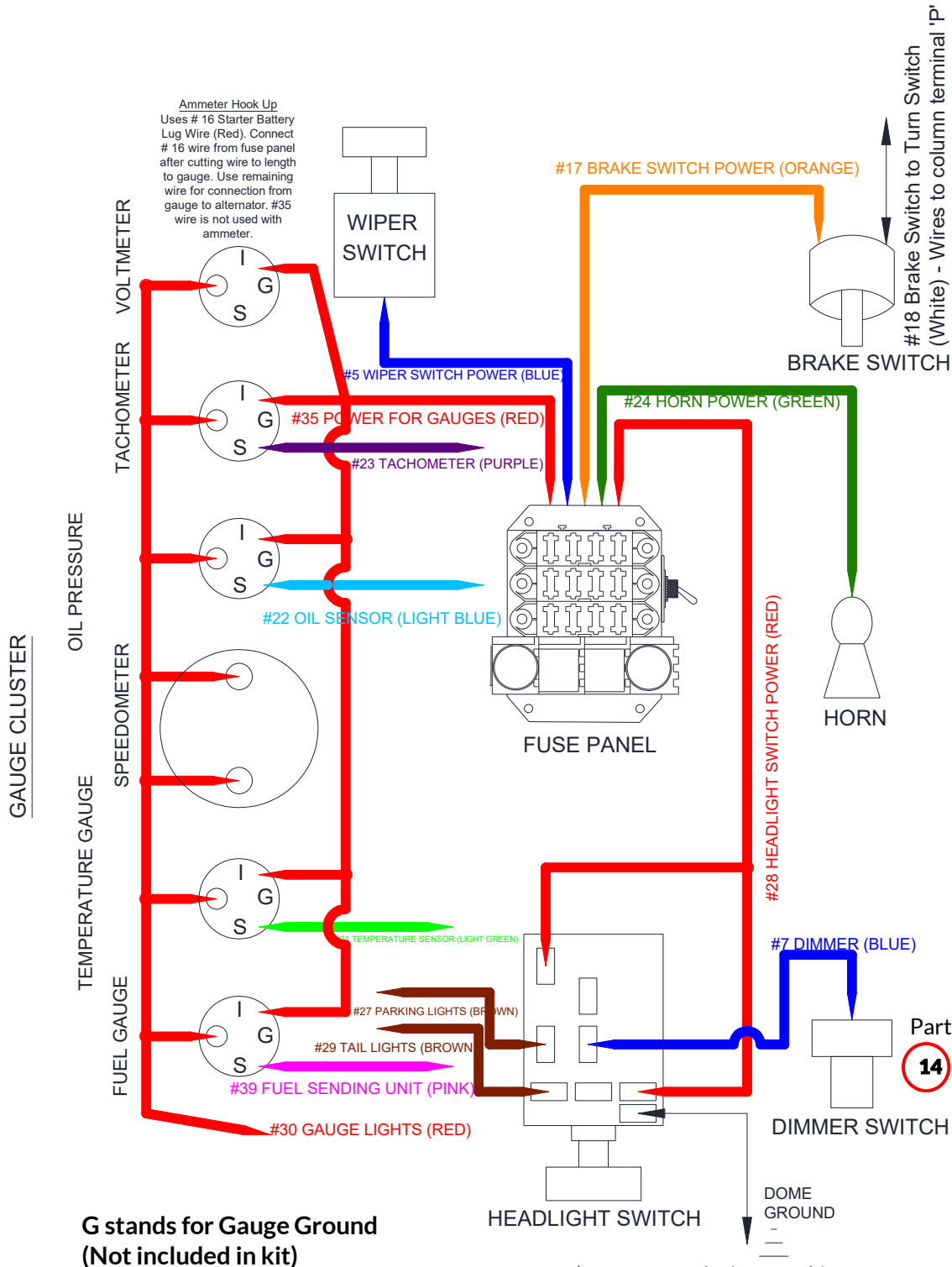

\*If using original 6 Volt gauges in a 12 Volt system, a voltage reducer must be used in line with #35 for each gauge.

\*Fuse panel pictured is our standard kit

# G.M. Column/Turn Signal Group

**# 53 Black 18 Ga. (Relay Ground for Horn)**

Originates from the horn relay located on the fuse panel and connects to the "G" terminal on the GM turn signal plug. **(Horn button is self grounded through column . Only attach #53 to horn button) (Refer to page 27 for horn detail)**

**# 52 Purple 14 Ga. (Turn Signal Flasher)**

Originates from the turn flasher located on the fuse panel and connects to the "L" terminal on the GM turn signal plug.

**# 51 Brown 14 Ga. (Emergency Flasher)**

Originates from the turn flasher located on the fuse panel and connects to the "K" terminal on the GM turn signal plug.

**# 49 Yellow 14 Ga. (Left Rear Turn Signal)**

Originates from the "M" terminal of the GM turn signal plug and connects to the left rear turn signal.

**# 48 Light Green 14 Ga. (Right Rear Turn Signal)**

Originates from the "N" terminal of the GM turn signal plug and connects to the right rear turn signal.

**\*\* WHEN INSTALLING LED LIGHTS YOU NEED TO INSTALL AN ELECTRONIC LED FLASHER OR 1 LOAD RESISTOR WITH #48 AND 1 WITH #49 WIRE FOR PROPER FLASHING. ONE WIRE GETS SPLICED IN LINE AND THE OTHER GETS GROUNDED\*\***

LOAD RESISTOR KIT—PART SKU-115 SOLD SEPARATELY (2 RESISTORS INCLUDED IN KIT)

ELECTRONIC LED FLASHER— PART SKU-12ANL

**# 26 Light Blue 16 Ga. (Front Left Turn Signal)**

Originates from the "H" terminal of the GM turn signal plug and connects to the left front turn signal.

**# 25 Blue 16 Ga. (Front Right Turn Signal)**

Originates from the "J" terminal of the GM turn signal plug and connects to the right front turn signal.

**# 18 White 14 Ga. (Brake Switch to Turn Switch)**

Originates from the brake switch and connects to the turn signal switch terminal "P" and is **main power for column.**

Factory wiring diagrams are available for an extra cost and come in color and are laminated. Order via [Kwik-Wire.com](http://Kwik-Wire.com) for correct year, make, and model selection.

11" x 17" \$30  
18" x 24" \$40

Part **6**

**Early Model**

**Late Model**

Part **2**

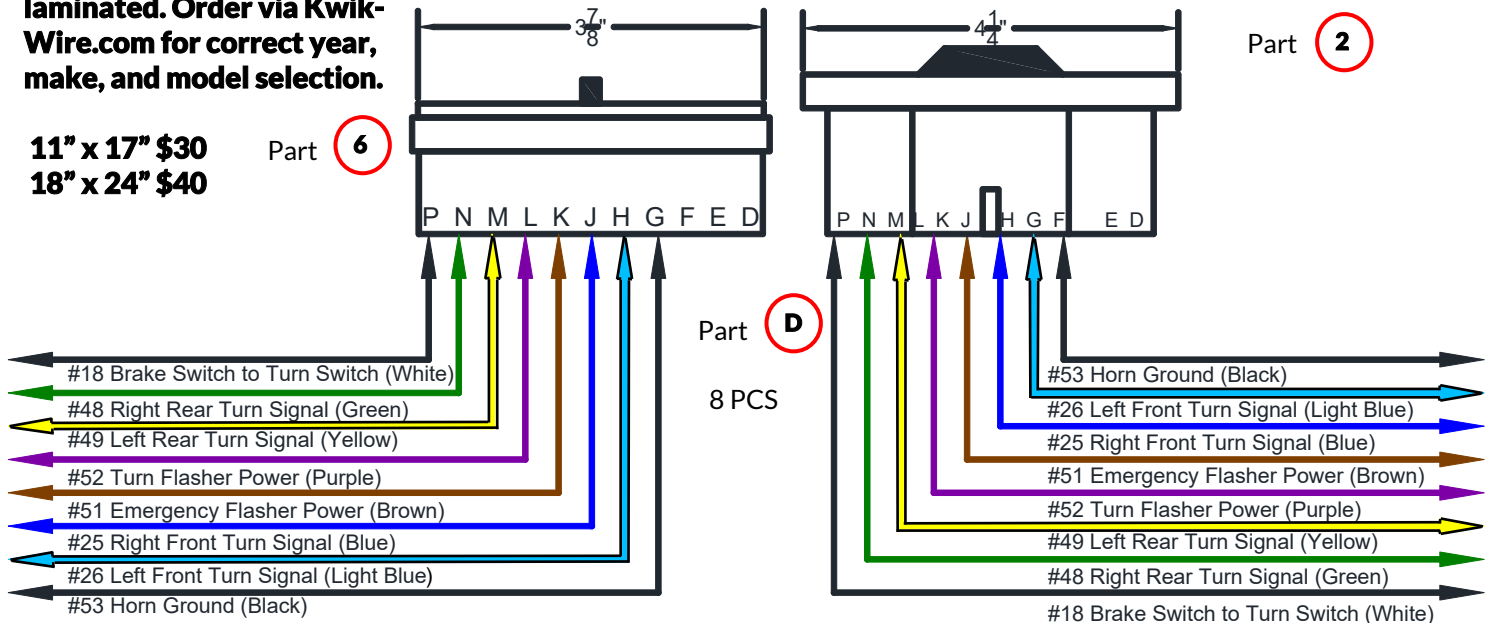

# Ford Column/Turn Signal Group

# 53 Black 18 Ga. (Relay Ground for Horn)

Originates from the horn relay located on the fuse panel and connects to the "G" terminal on the GM turn signal plug. **(Horn button is self grounded through column . Only attach #53 to horn button) (Refer to page 26 for horn detail)**

# 52 Purple 14 Ga. (Turn Signal Flasher)

Originates from the turn flasher located on the fuse panel and connects to the "L" terminal on the GM turn signal plug.

# 51 Brown 14 Ga. (Emergency Flasher)

Originates from the turn flasher located on the fuse panel and connects to the "K" terminal on the GM turn signal plug.

# 49 Yellow 14 Ga. (Left Rear Turn Signal)

Originates from the "M" terminal of the GM turn signal plug and connects to the left rear turn signal.

# 48 Light Green 14 Ga. (Right Rear Turn Signal)

Originates from the "N" terminal of the GM turn signal plug and connects to the right rear turn signal.

**\*\* WHEN INSTALLING LED LIGHTS YOU NEED TO INSTALL AN ELECTRONIC LED FLASHER OR 1 LOAD RESISTOR WITH #48 AND 1 WITH #49 WIRE FOR PROPER FLASHING. ONE WIRE GETS SPLICED IN LINE AND THE OTHER GETS GROUNDED\*\***

LOAD RESISTOR KIT—PART SKU-115 SOLD SEPARATELY (2 RESISTORS INCLUDED IN KIT)

ELECTRONIC LED FLASHER— PART SKU-12ANL

# 26 Light Blue 16 Ga. (Front Left Turn Signal)

Originates from the "H" terminal of the GM turn signal plug and connects to the left front turn signal.

# 25 Blue 16 Ga. (Front Right Turn Signal)

Originates from the "J" terminal of the GM turn signal plug and connects to the right front turn signal.

# 18 White 14 Ga. (Brake Switch to Turn Switch)

Originates from the brake switch and connects to the turn signal switch terminal "P" and is **main column power.**

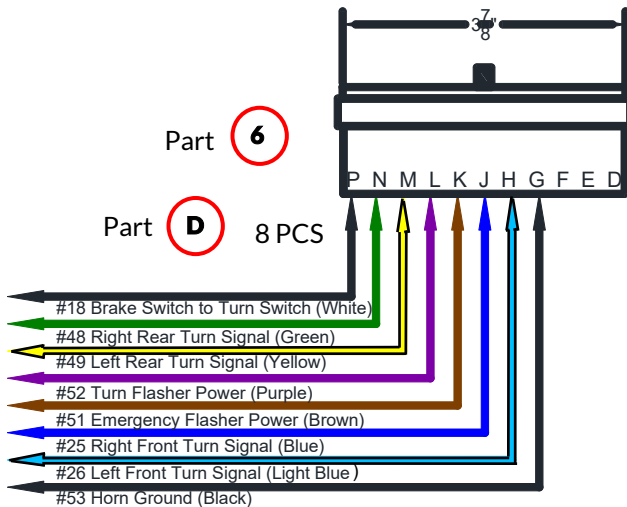

**\*\*\*You must cut terminals from existing column and use included mating GM plugs and terminals.\*\*\***

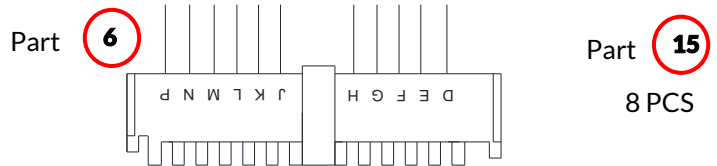

## 70-75 Ford Column/Turn Signal Group

White / Blue	Right Front Turn
White / Red	Emergency Flasher
Green / White	Left Front Turn
Green/Orange	Left Rear Turn
Orange / Blue	Right Rear Turn
Green	Brake Light
Blue	Power for turn signals

Black / Green	Ignition Accessory
Black	Ignition Coil
Brown / Purple	Starter
Yellow	Ignition Power

\*See Pg 37 for additional Ford Column Connections.

**\*\* Cross-referenced For General Purposes Only\*\***  
**Full factory wiring diagrams are available for an extra cost and come in color and are laminated. Order via KwikWire.com for correct year, make, and model selection.**

11" x 17" \$30

18" x 24" \$40



# Ford Turn Signal Plugs

## With Hazards

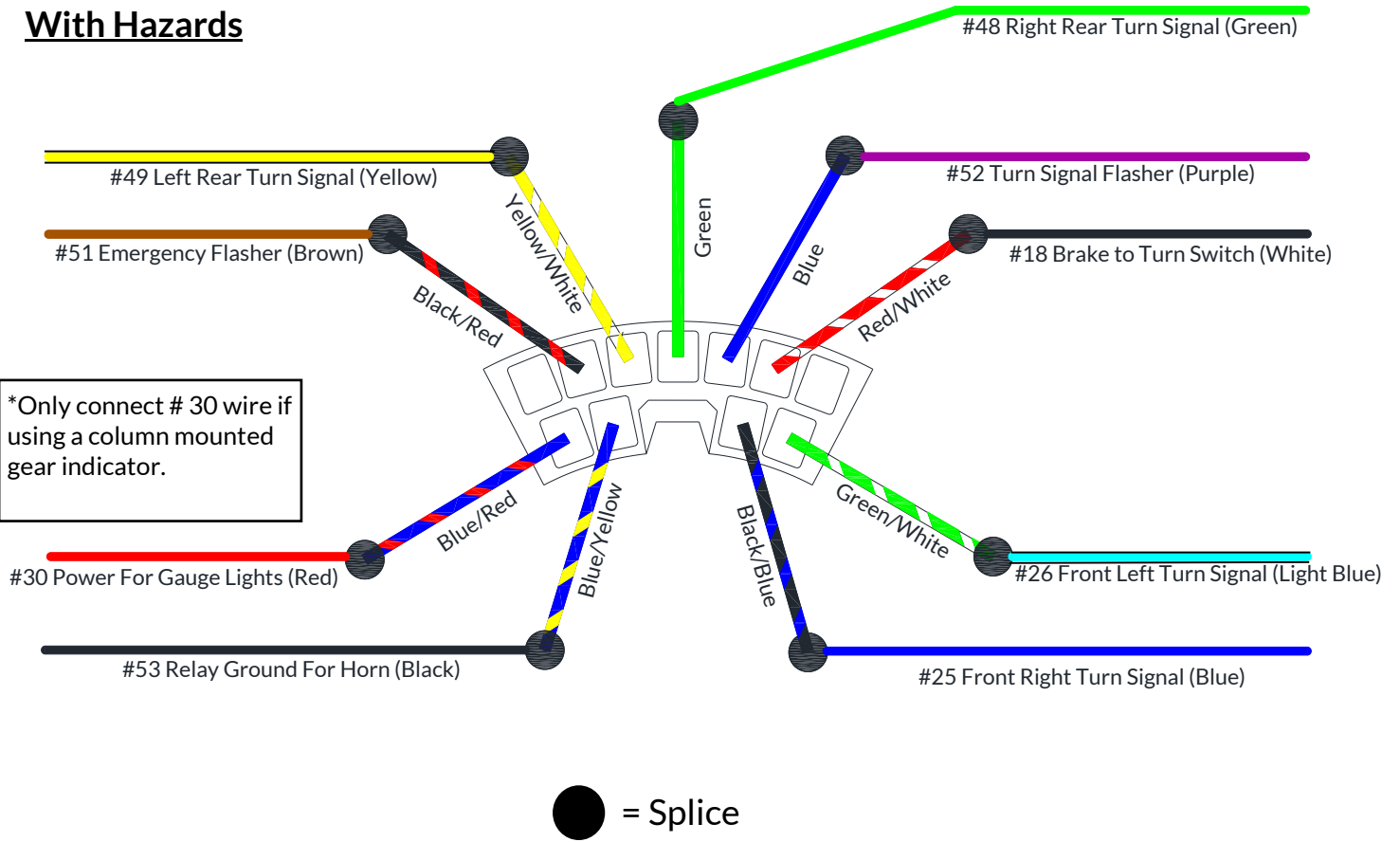

## Without Hazards

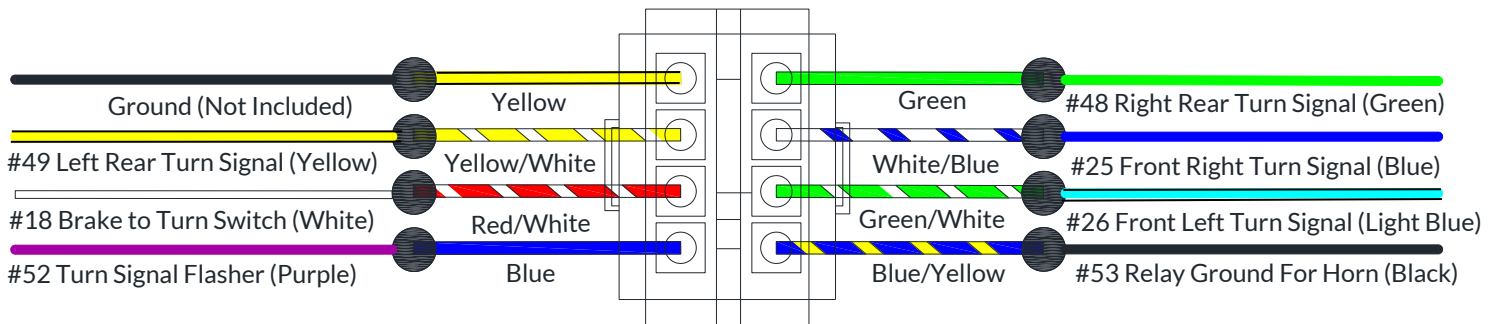

# Chrysler Column/Turn Signal Group

# 53 Black 18 Ga. (Relay Ground for Horn)

Originates from the horn relay located on the fuse panel and connects to the “G” terminal on the GM turn signal plug.  
**(Horn button is self grounded through column . Only attach #53 to horn button) (Refer to page 27 for horn detail)**

# 52 Purple 14 Ga. (Turn Signal Flasher)

Originates from the turn flasher located on the fuse panel and connects to the “L” terminal on the GM turn signal plug.

# 51 Brown 14 Ga. (Emergency Flasher)

Originates from the turn flasher located on the fuse panel and connects to the “K” terminal on the GM turn signal plug.

# 49 Yellow 14 Ga. (Left Rear Turn Signal)

Originates from the “M” terminal of the GM turn signal plug and connects to the left rear turn signal.

# 48 Light Green 14 Ga. (Right Rear Turn Signal)

Originates from the “N” terminal of the GM turn signal plug and connects to the right rear turn signal.

**\*\* WHEN INSTALLING LED LIGHTS YOU NEED TO INSTALL AN ELECTRONIC LED FLASHER OR 1 LOAD RESISTOR WITH #48 AND 1 WITH #49 WIRE FOR PROPER FLASHING. ONE WIRE GETS SPLICED IN LINE AND THE OTHER GETS GROUNDED\*\***  
**LOAD RESISTOR KIT—PART SKU-115 SOLD SEPARATELY (2 RESISTORS INCLUDED IN KIT)**  
**ELECTRONIC LED FLASHER— PART SKU-12ANL**

# 26 Light Blue 16 Ga. (Front Left Turn Signal)

Originates from the “H” terminal of the GM turn signal plug and connects to the left front turn signal.

# 25 Blue 16 Ga. (Front Right Turn Signal)

Originates from the “J” terminal of the GM turn signal plug and connects to the right front turn signal.

# 18 White 14 Ga. (Brake Switch to Turn Switch)

Originates from the brake switch and connects to the turn signal switch terminal “P”.

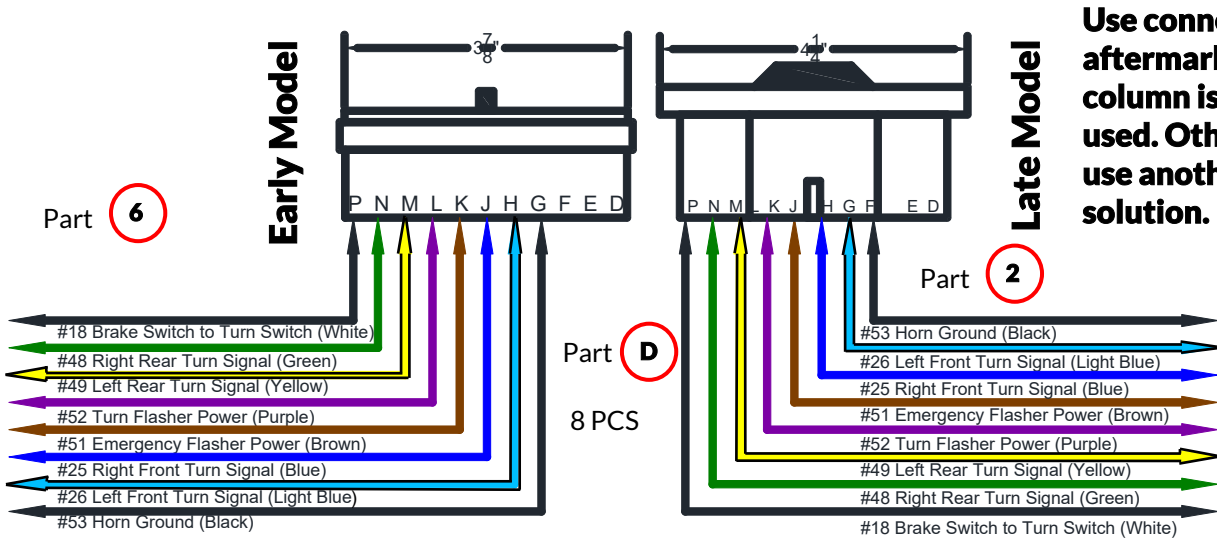

**Tan** Right Front Turn  
**Pink** Emergency Flasher  
**Green** Left Front Turn  
**Green** Left Rear Turn  
**Brown** Right Rear Turn  
**White** Brake Light  
**Red** Power for turn signals

**Blue** Ignition Accessory  
**Brown** Ignition Coil  
**Yellow** Starter  
**Red** Ignition Power

**\*\* Cross -referenced For General Purposes Only\*\***

**Full factory wiring diagrams are available for an extra cost and come in color and are laminated. Order via web for correct year, make, and model selection.**

**11" x 17" \$30**

**18" x 24" \$40**

# Turn Signal Connector Alignment

Late Model

From Column

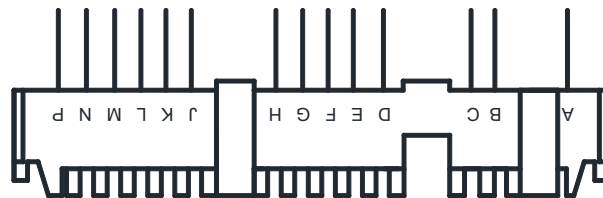

Connector not included in kits but it is available with terminals.

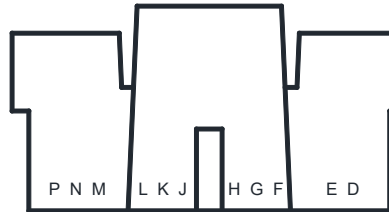

Part **2**

Early Model

From Column

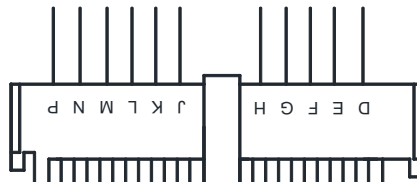

Part **15**

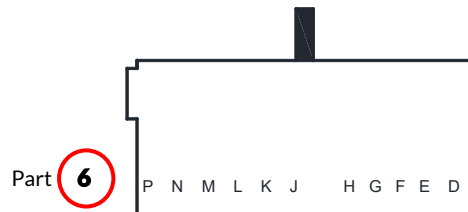

Part **6**

\*Early connectors included in Ford Kits

## After Market Turn Signal w/ Hazards Kwik Wire Part # 6020

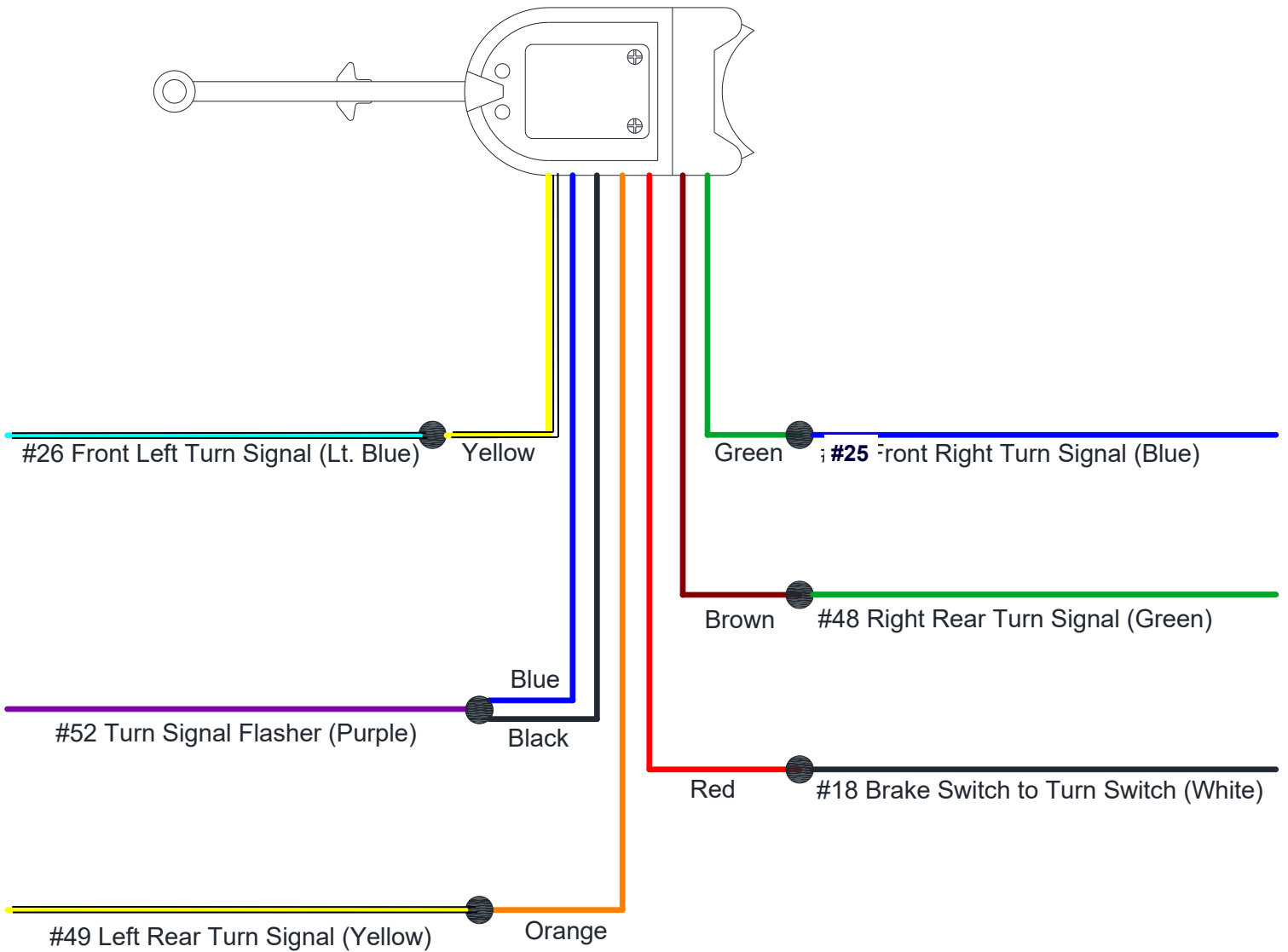

**Note: # 51 Hazard Flashers (Brown Wire)**  
Please disregard the hazard flasher wire. Hazards will flash using turn signal wire. We recommend removing fuse, capping and tucking wire for potential future use.

● = Splice

# After Market Turn Signal w/o Hazards Kwik Wire Part # 6020G

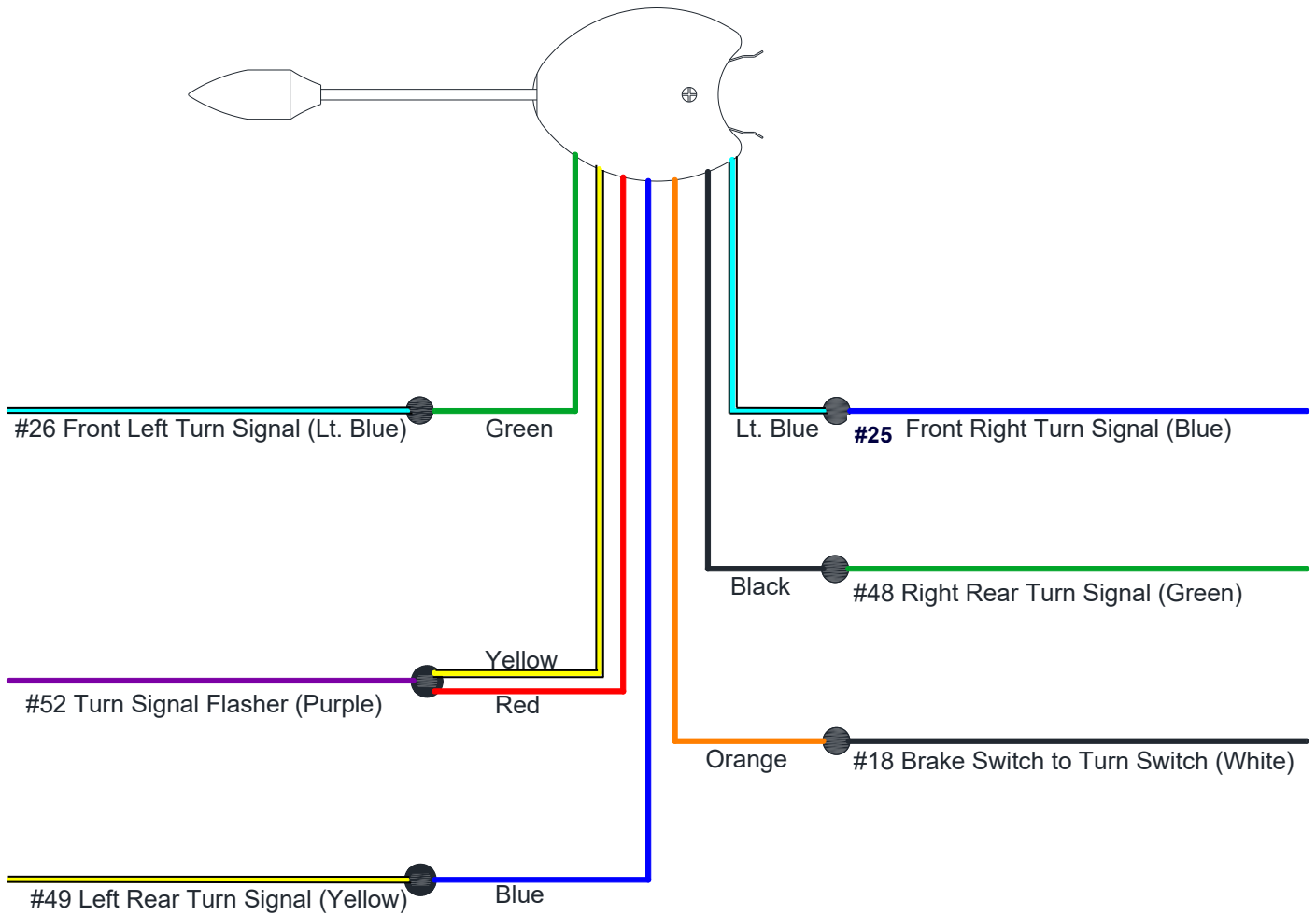

**Note: # 51 Hazard Flashers (Brown Wire)**  
Is not needed with this switch since it does not support hazard flashers.

● = Splice

## After Market Turn Signal Options (Continued)

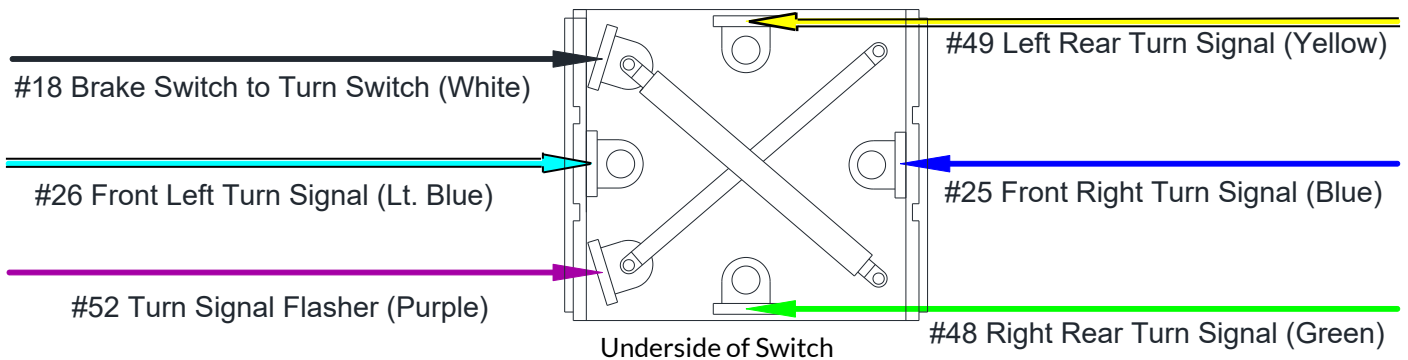

## Toggle Turn Signal Switch w/o Harness KW# 6022

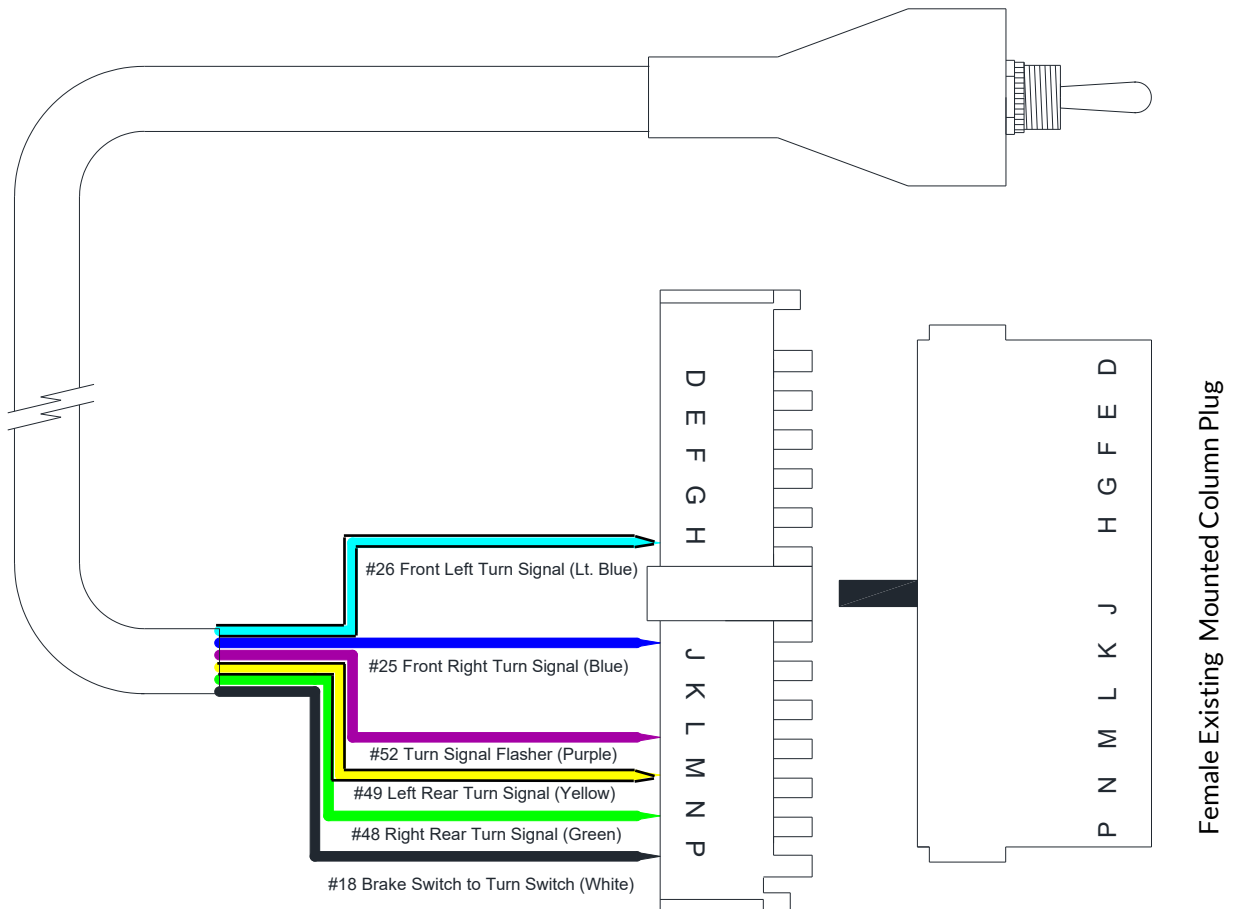

## Toggle Turn Signal Switch w/ Harness KW# 6021

# Headlight Switches

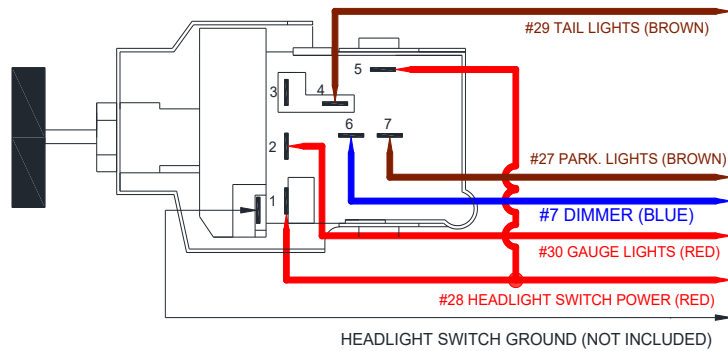

If installing HID headlights we **HIGHLY** recommend relaying to prevent headlight switch burnout.

2 light kit - Part #74

Wire Functions and connections for headlight switches are listed on page

## Early Style GM KW Part # 70701 & 70701A

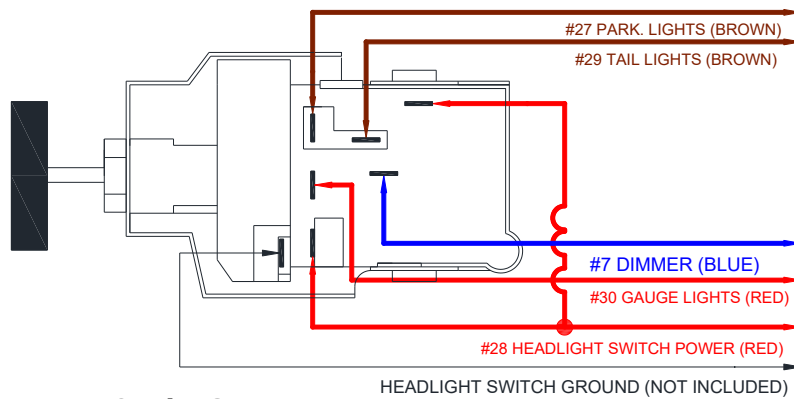

## Late Style GM

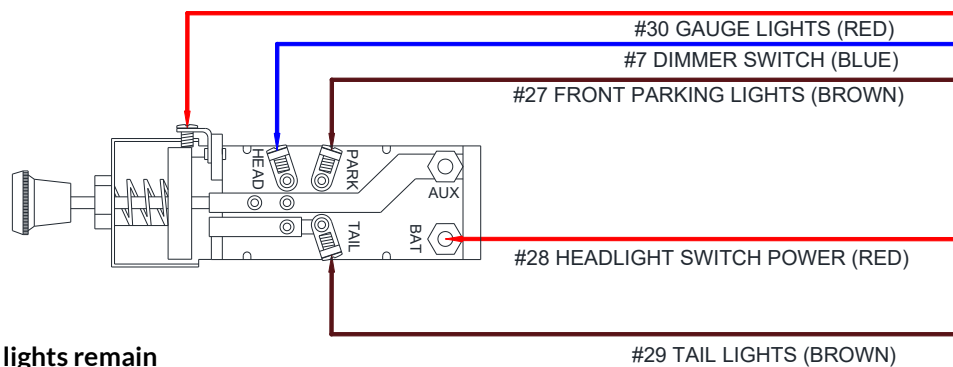

\*To have parking lights remain on when headlights are switched #27 and #29 will need to be Connected to same terminal

1947 to 1957  
KW Part# KW475901

Ford

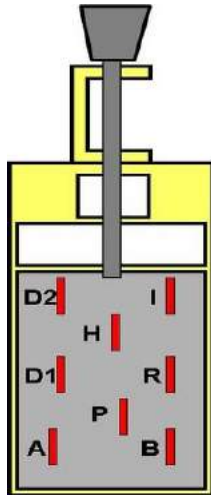

- |                         |               |                   |
|-------------------------|---------------|-------------------|
| B - Battery Feed        | Kit—Red #28   | Ford—Black/Orange |
| R - Tail Lamps          | Kit—Brown #29 | Ford—Black        |
| I - Dash Indicators     | Kit—Red #30   | Ford—Blue/Red     |
| P - Front Park Lamps    | Kit—Brown #27 | Ford—Black/Yellow |
| H - Headlights (Dimmer) | Kit—Blue #7   | Ford—Red/Yellow   |
| A - Brake Switch Feed   | Kit—Not Used  | Ford—Green/Red    |

No kit wires are supplied for D1 and D2 connections. Please refer to page 29 for wiring Ford dome lights with this switch.

DO NOT USE #45 for this switch since the headlight switch gives power

Mopar

To have park lamps function as factory (parking lights turn off when headlights are on) hook the #27 wire to the "P" Terminal

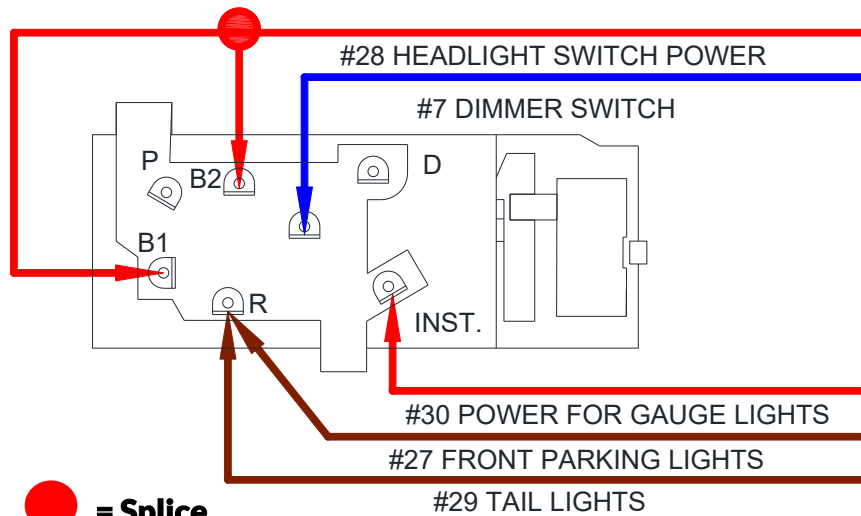

**# 30 Red 14 Ga. (Power for Gauge Lights)**

Originates from the headlight switch and connects to the dash lights. Jump wires from light to light.

**# 29 Brown 14 Ga. (Tail Lights)**

Originates from the headlight switch to the rear tail lights.

**# 28 Red 12 Ga. (Headlight Switch Power)**

Originates from the fuse panel and connects to the battery post on headlight switch.

**# 27 Brown 16 Ga. (Front Parking Lights)**

Originates from the headlight switch and connects to the front parking lights.

**# 7 Blue 12 Ga. (Dimmer Switch)**

Originates from the headlight switch and connects to the floor mounted or column dimmer switch.

\*To have parking lights remain on when headlights are switched #27 and #29 will need to be Connected to same terminal

**Note: See page 29 for dome light diagram.**



# Toggle/Rocker Headlight Switches

## Non-Lighted SPST Switch

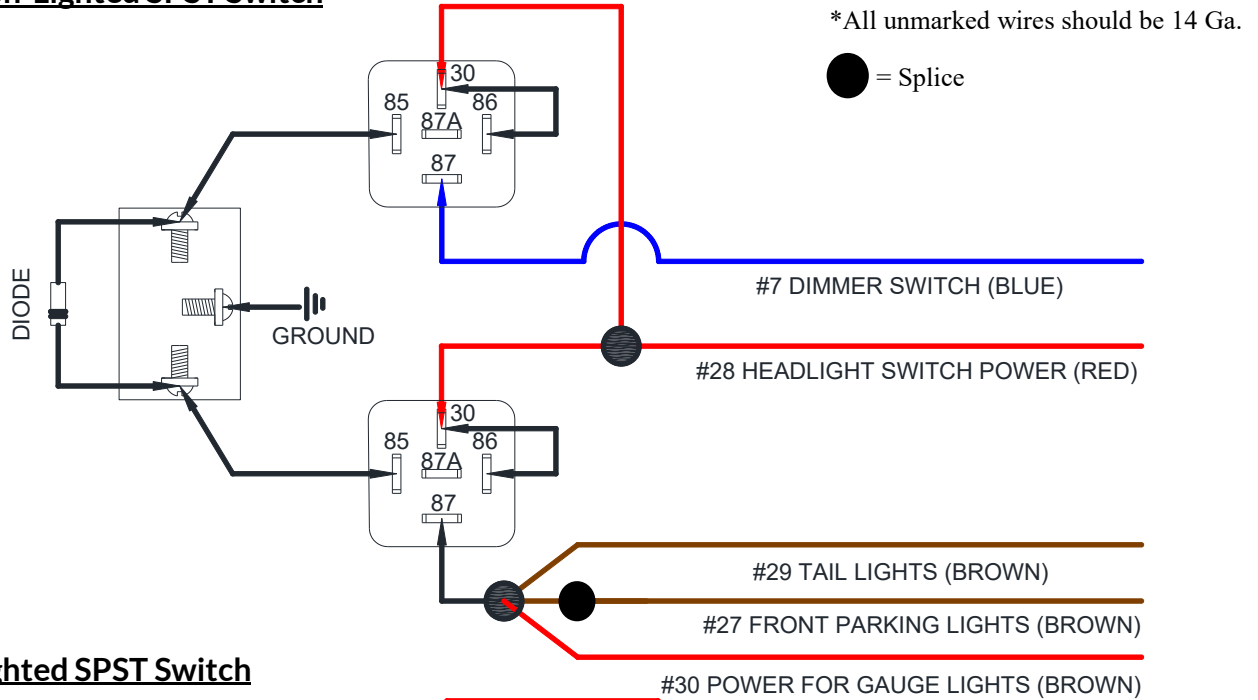

## Lighted SPST Switch

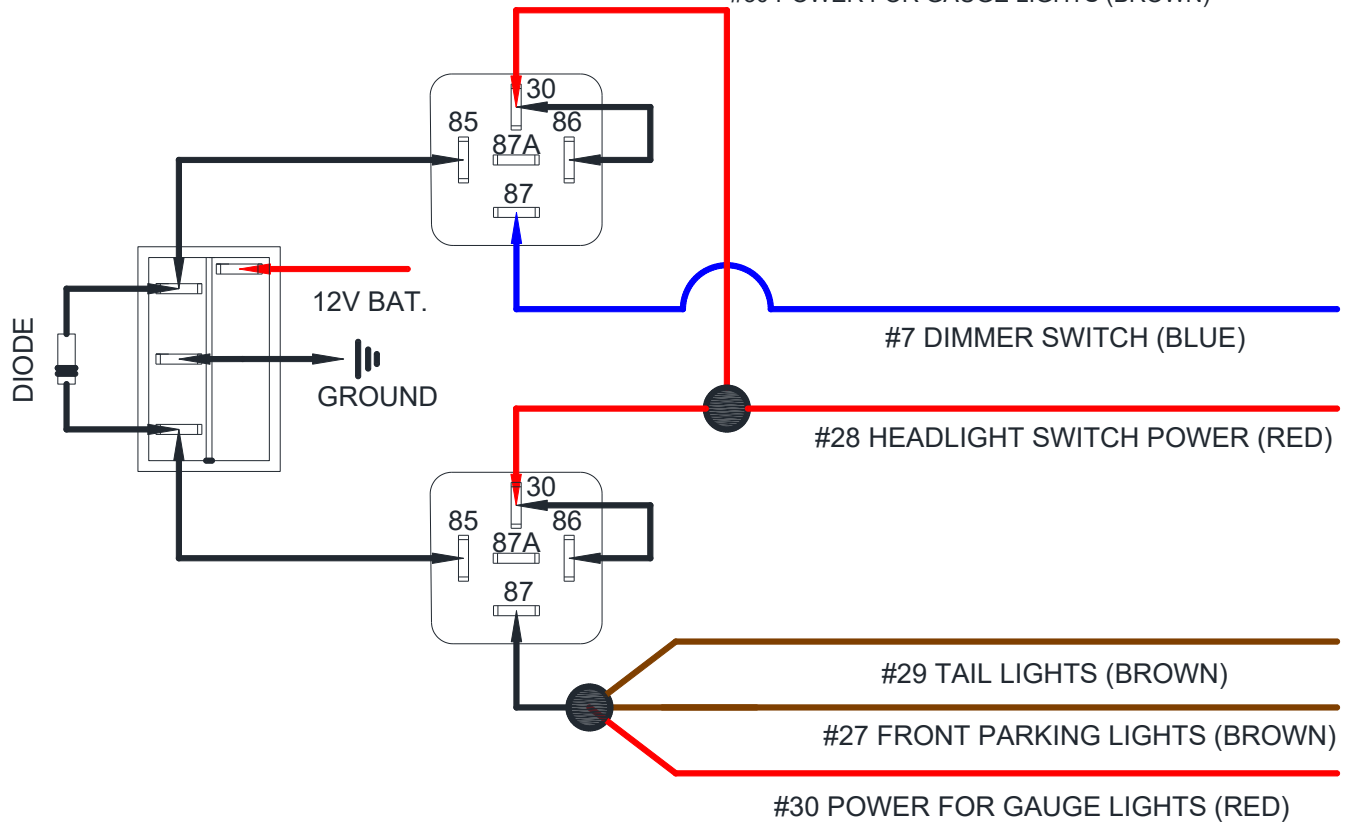

# Dimmer Switch

# 7 Blue 12 Ga (Dimmer Switch) Originates from the headlight switch and connects to the dimmer switch .

# 8 Lt Green 14 Ga (High Beam) Originates from the dimmer switch and connects to the high beam headlights .

# 9 Tan 14 Ga (Low Beam) Originates from the dimmer switch and connects to the low beam headlights.

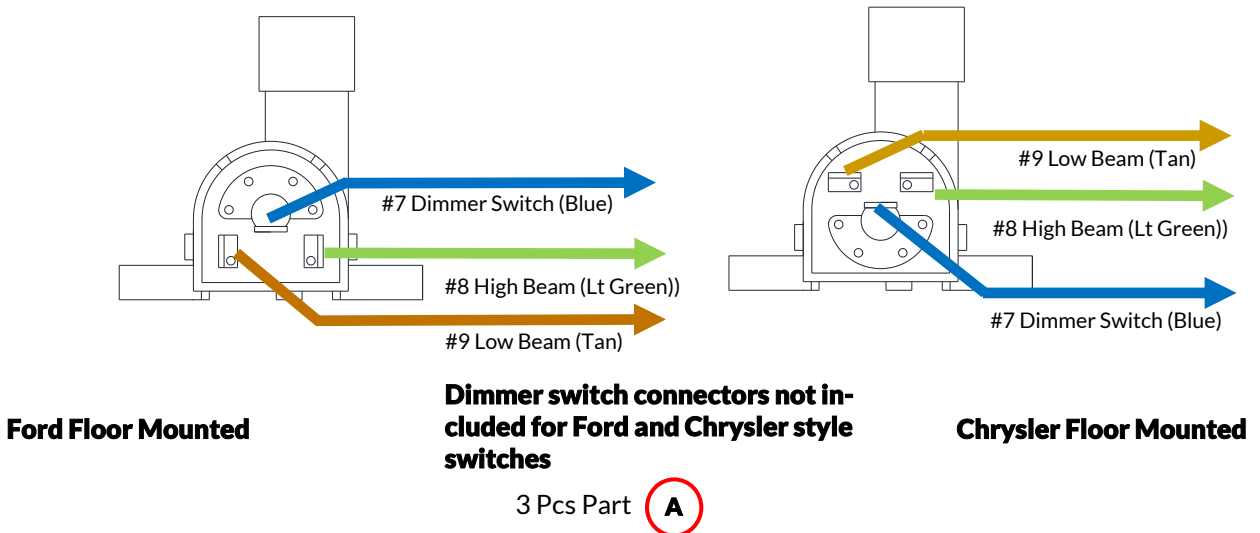
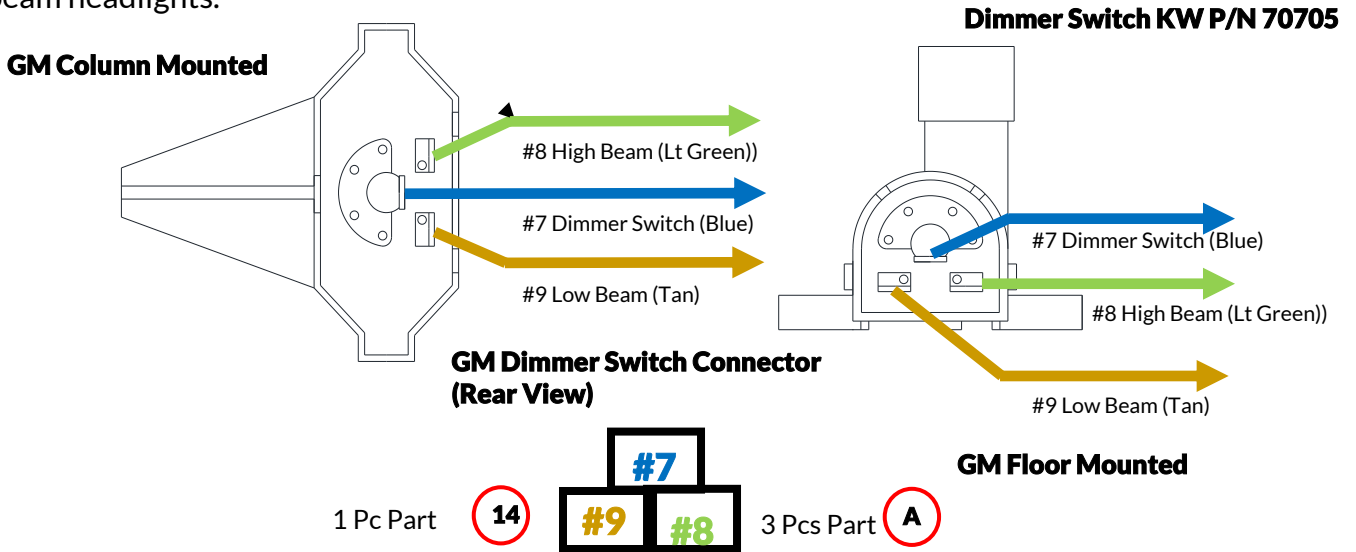

# Radio Group

## **# 40 Red 18 Ga. (Radio Constant)**

Originates from the fuse panel and connects to the radio memory wire.

## **# 41 Red 18 Ga. (Radio Ignition)**

Originates from the fuse panel and connects to the radio ignition hot wire.

## **# 42 Purple 18 Ga. (Power Antenna Signal) - 22 Circuit Harnesses Only**

Originates from the radio group and connects to signal wire on your power antenna.

## **# 43 Red 18 Ga. (Power Antenna) - 22 Circuit Harnesses Only**

Originates from fuse panel and connects to 12 volt power wire on your power antenna.

## **Clear +/- 16 Ga. Speaker Wire (No Print)**

Originates from the radio group and connects to the rear speaker.

**\*Budget harnesses do not include speaker wire.**

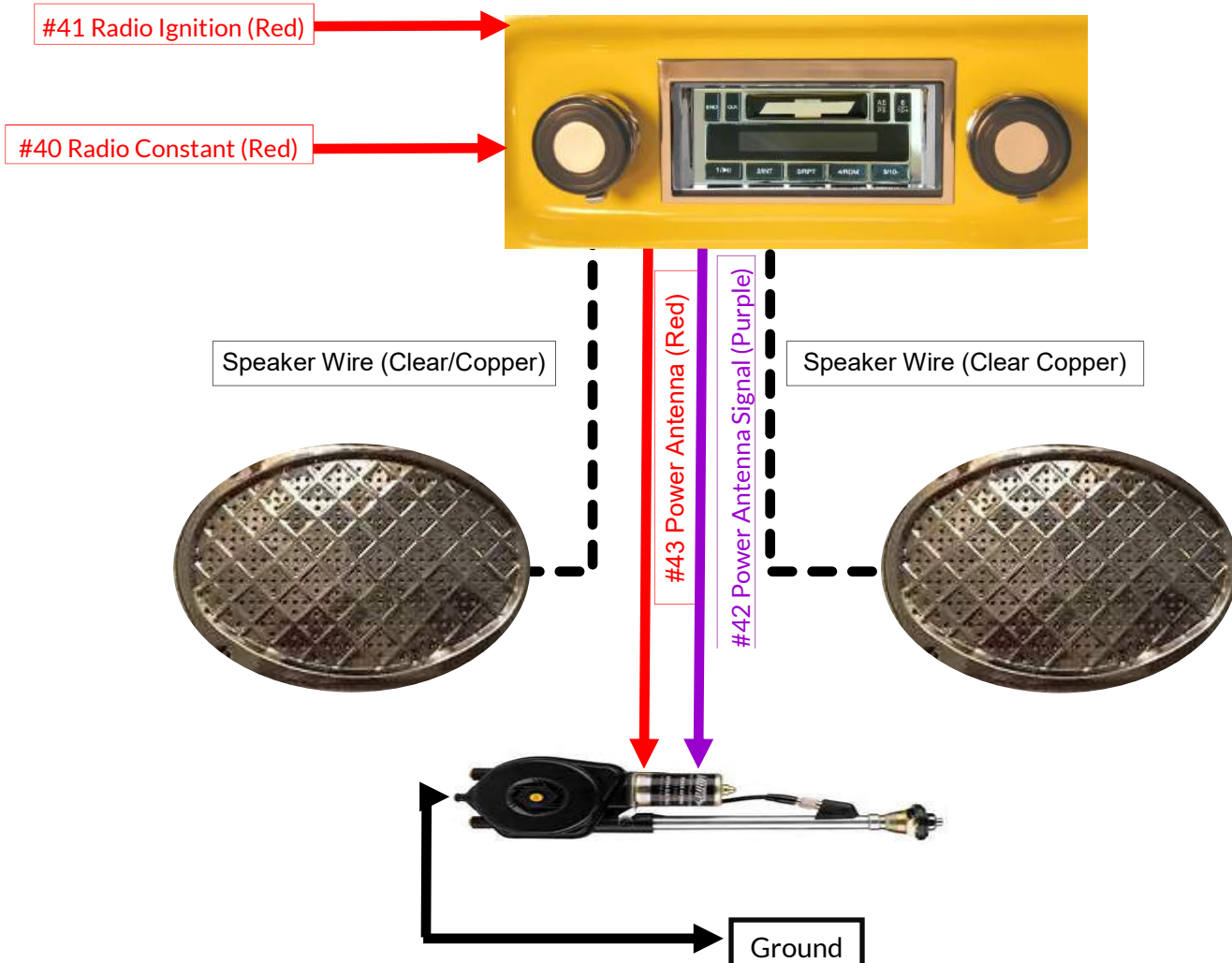

# Cruise Control / Back-up / Accessories

**\*\*20 and 22 Circuit Kwik Wire Harness ONLY\*\***

**# 57 Pink 18 Ga. (Cruise Control Power)**

Originates from the fuse panel and connects to the cruise control power wire.

**\*\*Included in all kits\*\***

**# 56 Green 18 Ga. (Back-up Lights)**

Originates from the back up light switch and connects to the back up lights.

**\*\*14, 20, and 22 Circuit Kwik Wire Harness ONLY\*\***

**# 58 Light Green 18 Ga. (Back-up Light Switch Power)**

Originates from the fuse panel and connects to the back up light switch power wire.

**\*\*20 and 22 Circuit Kwik Wire Harness ONLY\*\***

**— Power Door D-1 Group —**

**# 10 Yellow 14 Ga. (Right Door Lock)**

Originates from fuse panel and connects to power wire on right power door locks.

**# 11 Yellow 12 Ga. (Right Power Window)**

Originates from fuse panel and connects to power wire on right power window switch.

**\*\*20 and 22 Circuit Kwik Wire Harness ONLY\*\***

**— Power Door D-2 Group —**

**# 12 Yellow 14 Ga. (Left Door Lock)**

Originates from the fuse panel and connects to the power wire on the left power door locks.

**# 13 Yellow 12 Ga. (Left Power Window)**

Originates from the fuse panel and connects to power wire on the left power window switch.

**\*\*22 Circuit Kwik Wire Harness ONLY\*\***

**— Accessories—**

**#60 Orange 14 Ga. (Extra Constant Hot)**

Originates from the fuse panel and connects to the power wire on desired component.

**#61 Blue 14 Ga. (Extra Constant Hot)**

Originates from the fuse panel and connects to the power wire on desired component.

# Brake Switch

## Hydraulic Brake Switch

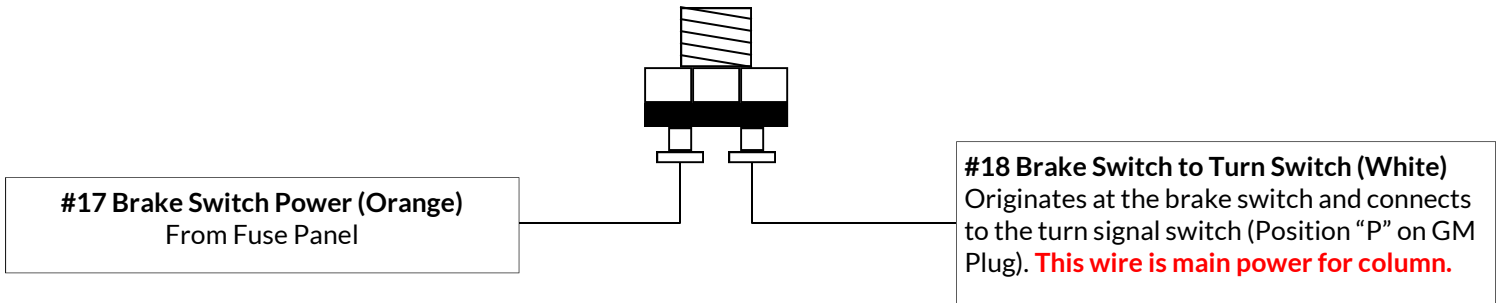

## Push Button Stop Switch

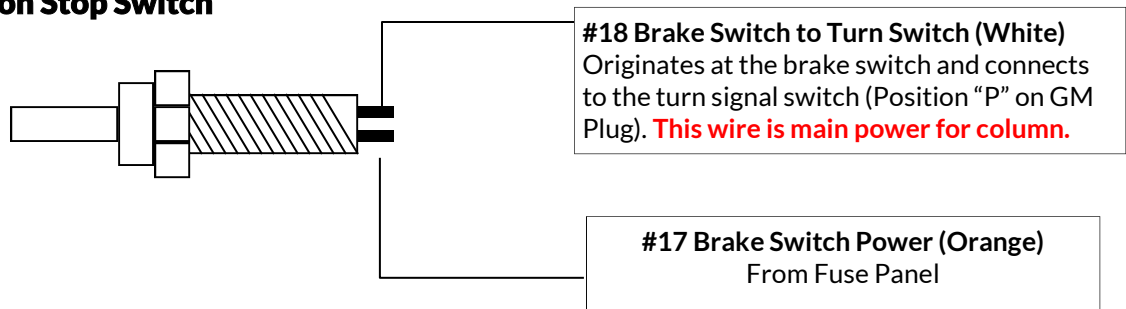

### # 17 Orange 14 Ga. (Brake Switch Power)

Connect to battery side of brake switch.

### # 18 White 14 Ga. (Brake Switch to Turn Switch)

Originates from the brake light switch and hook to turn signal switch. **This wire is main power for column.**

# Tail Lights

## #29 Brown 14 Ga. (Tail Light)

Originates from the headlight switch and connects to the tail lights and also the license plate light.

## #48 Green 14 Ga. (Right Rear Turn Signal)

Originates from the turn signal switch and connects to the right rear turn lamp.

## #49 Yellow 14 Ga. (Left Rear Turn Signal)

Originates from the turn signal switch and connects to the left rear turn lamp.

**\*\* WHEN INSTALLING LED LIGHTS YOU NEED TO INSTALL AN ELECTRONIC LED FLASHER OR 1 LOAD RESISTOR WITH #48 AND 1 WITH #49 WIRE FOR PROPER FLASHING. ONE WIRE GETS SPLICED IN LINE AND THE OTHER GETS GROUNDED\*\* THIS CONNECTION WILL TAKE CARE OF FLASHING FRONT AND BACK LIGHTS LOAD RESISTOR KIT—PART SKU-115 SOLD SEPARATELY (2 RESISTORS INCLUDED IN KIT) ELECTRONIC LED FLASHER— PART SKU-12ANL**

*Note: On most applications, the brake lights and turn signal wires are the same filament. In this situation you only need to hook up wires # 48 & # 49 the brake lights will work through the turn signal switch on the column.*

## #55 Orange 18 Ga. (Third Brake Light)

Originates from the brake light wire #18 and connects to the third brake light **ONLY**.

If not installing third brake light cap and tie up wire. (Wire not pictured below)

## # 56 Green 18 Ga. (Back up Lights)

Originates from the back up light switch and connects to the rear back up lights.

**\*\*Make sure fuel tank and all lights are grounded to a good clean ground\*\***

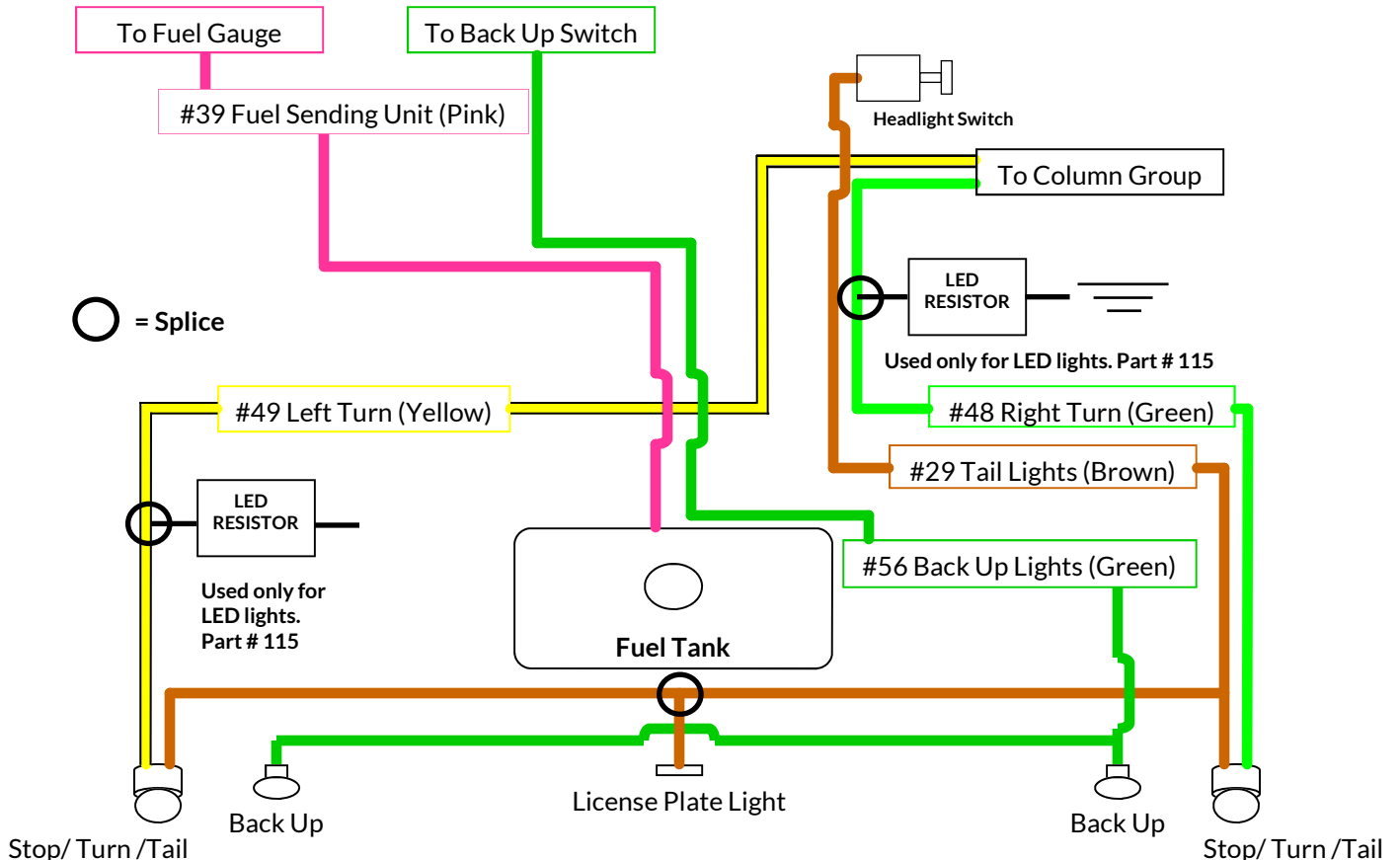

# Tail Group

## # 39 Pink 16 Ga. (Fuel Sending Unit)

Originates from the fuel sender and connects to the fuel gauge "S" terminal.

## # 47 Yellow 14 Ga. (Electric Fuel Pump Power)

Originates from the fuse panel and connects to the fuel pump.

\*\*\*8 Circuit Harness has fuel pump relay installed\*\*\*

**Otherwise you may need to relay the fuel pump. Check the fuel pump instructions.**

## # 42 Purple 18 Ga. (Power Antenna Signal) (22 Circuit Kits Only) (See page 47)

Originates from the Radio Group and connects to the power antenna signal wire.

## # 43 Red 18 Ga. (Power Antenna) (22 Circuit Kits Only) (See page 47)

Originates from the fuse panel and connects to the power antenna power wire.

## # 46 Green 16 Ga. (Trunk Light Power)

Originates from the fuse panel and connects to the positive side of the trunk light.

### – Fuel Pump Relay –

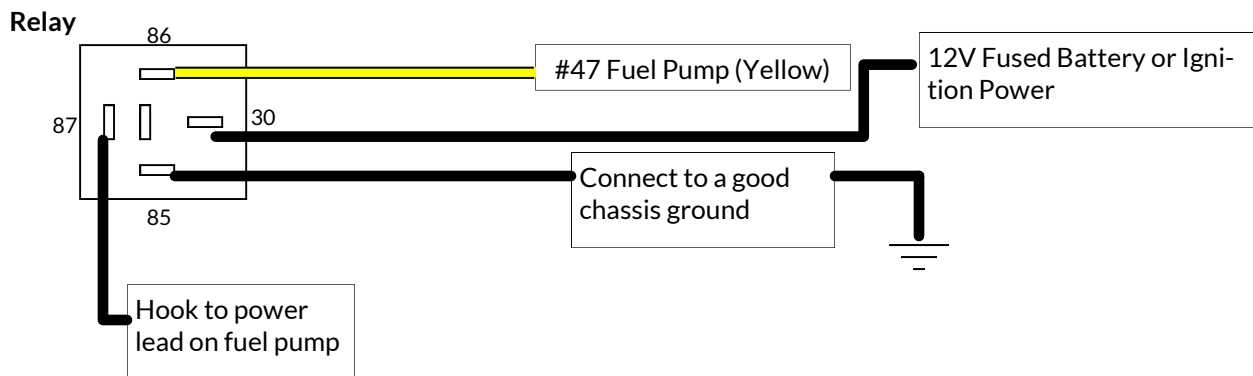

### – Fuel Sending Unit –

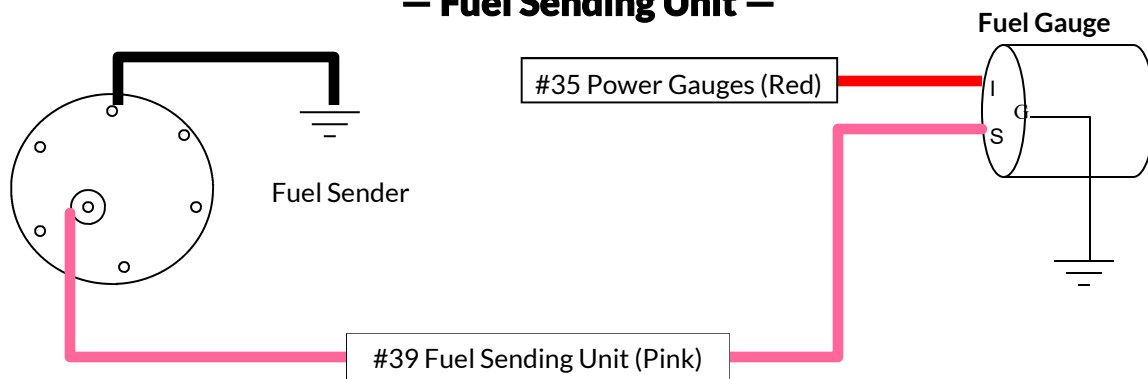

# Fuse Charts

## 22 Circuit Harness

Function	Amp Fuse
Hazard	25
Horn	20
Dome / Trunk Light	10
Cigarette Lighter	20
Fuel	15
Wiper / Electric Choke	15
Gauges	10
Electric Fan	25
Power Windows	30
Stop	20
Power Door Locks	20
Back-Up / Cruise	20
Headlights	25
Accessory	20
Radio Const./Pwr. Ant.	10
Accessory	20
A/C Heat	30
Radio Ignition	10
Turn	15
Coil	30

## 14 Circuit Harness

Function	Amp Fuse
Stop/ Radio Constant	20
Horn	20
Headlights	25
Dome/Hazard	25
Fuel Pump	15
Radio Ignition	10
Gauges	10
Coil	30
Electric Fan	25
Wiper / Back-up	15
A/C Heat	30
Turn Signal	15

## 8 Circuit Harness

Function	Amp Fuse
Turn / Wiper	20
Radio Ignition	10
Gauges	10
Fuel Pump/Back-up	15
Hazard	25
Headlights	25
Stop / Horn	20
Coil	30

## 20 Circuit Harness

Hazard	25
Horn	20
Dome/Trunk	10
Cig Lighter	20
Fuel Pump	25
Wipers/Elec. Choke	15
Back-Up/Cruise	20
Electric Fan	25
Power Windows	20
Stop/Radio Const.	20
Power Door Locks	30
Headlights	25
A/C Heat	30
Radio Ign / Gauges	10
Turn Signal	15
Coil	30

### \*Only Use Recommended Fuses

**Note: This Instruction book will cover all Kwik Wire harnesses. Not all wires listed in the instruction book will be in your harness depending on size fuse panel you purchased.**



## Wire Function Index

#	Label	Function	Color	Ga.	8	14	20	22
1	Electric Cooling Fan	Switched Wire	Gray	14	X	✓	✓	✓
2	A/C Compressor	Switched Wire	Black	14	X	✓	✓	✓
3	Cigarette Lighter Power	Constant Hot Wire	Tan	14	X	X	✓	✓
4	A/C -Heat Switch Power	Ignition Hot Wire	Black	14	X	✓	✓	✓
5	Wiper Switch Power	Ignition Hot Wire	Blue	16	✓	✓	✓	✓
6	El. Fan Sw. Pwr- <b>Budgets</b>	Ignition Hot Wire	Gray	14	X	✓	✓	✓
7	Dimmer Switch	Headlight Switch Power	Blue	12	✓	✓	✓	✓
8	High Beam	Headlight Switch Power	Lt. Green	14	✓	✓	✓	✓
9	Low Beam	Headlight Switch Power	Tan	14	✓	✓	✓	✓
10	Right Door Lock	Constant Hot Wire	Yellow	14	X	X	✓	✓
11	Right Power Window	Ignition Hot Wire	Yellow	12	X	X	✓	✓
12	Left Door Lock	Constant Hot Wire	Yellow	14	X	X	✓	✓
13	Left Power Window	Ignition Hot Wire	Yellow	12	X	X	✓	✓
14	Alternator Exciter	Ign. Hot (Not Fused)	White	16	✓	✓	✓	✓
16	Starter Battery Lug	Const. Hot (In Line Fuse)	Red	10	✓	✓	✓	✓
17	Brake Switch Power	Constant Hot Wire	Orange	14	✓	✓	✓	✓
18	Brake Sw. to Turn Switch	Switched Wire	White	14	✓	✓	✓	✓
19	Neutral Safety Switch	Switched Wire	Purple	12	✓	✓	✓	✓
20	+ Side of Coil or HEI	Hot in Run & Start Pos.	Pink	14	✓	✓	✓	✓
21	Temperature Sender	Sending Unit Wire	Green	18	✓	✓	✓	✓
22	Oil Pressure Sender	Sending Unit Wire	Lt. Blue	18	✓	✓	✓	✓
23	Tachometer	Sending Unit Wire	Purple	18	✓	✓	✓	✓
24	Horn	Constant Hot Wire	Green	14	✓	✓	✓	✓
25	Front Right Turn Signal	Switched Wire	Blue	16	✓	✓	✓	✓
26	Front Left Turn Signal	Switched Wire	Lt. Blue	16	✓	✓	✓	✓
27	Front Parking Lights	Headlight Switch Power	Brown	16	✓	✓	✓	✓
28	Headlight Switch Power	Constant Hot Wire	Red	12	✓	✓	✓	✓
29	Tail Lights	Headlight Switch Power	Brown	14	✓	✓	✓	✓
30	Power For Gauge Lights	Headlight Switch Power	Red	14	✓	✓	✓	✓

 Pre Connected Wires

 Loose Wires (2 Ends)

**Wire Function Index**

#	Label	Function	Color	Ga.	8	14	20	22
31	Ignition Coil	Ignition Hot Wire	Pink	14	✓	✓	✓	✓
32	Ignition Accessory	Ignition Hot (Not Fused)	Brown	12	✗	✗	✗	✓
33	Ignition Accessory	Ignition Hot (Not Fused)	Orange	12	✓	✓	✓	✓
34	Ignition Power	Constant Hot (Not Fused)	Red	12	✓	✓	✓	✓
35	Power For Gauges	Ignition Hot Wire	Red	16	✓	✓	✓	✓
36	High Beam Indicator	Indicator	Green	18	✓	✓	✓	✓
37	Left Turn Indicator	Indicator	Lt Blue	18	✓	✓	✓	✓
38	Right Turn Indicator	Indicator	Blue	18	✓	✓	✓	✓
39	Fuel Sending Unit	Sending Unit Wire	Pink	16	✓	✓	✓	✓
40	Radio Constant	Constant Hot Wire	Red	18	✗	✓	✓	✓
41	Radio Ignition	Ignition Hot Wire	Red	18	✓	✓	✓	✓
42	Power Antenna Signal	Switched Wire	Purple	18	✗	✗	✗	✓
43	Power Antenna	Constant Hot Wire	Red	18	✗	✗	✗	✓
45	Dome Light Power	Constant Hot Wire	White	16	✗	✓	✓	✓
46	Trunk Light Power	Constant Hot Wire	Green	16	✗	✗	✓	✓
47	Elec. Fuel Pump Pwr.	Ignition Hot Wire	Yellow	14	✓	✓	✓	✓
48	Right Rear Turn Signal	Switched Wire	Green	14	✓	✓	✓	✓
49	Left Rear Turn Signal	Switched Wire	Yellow	14	✓	✓	✓	✓
51	Emergency Flasher	Constant Hot Wire	Brown	14	✓	✓	✓	✓
52	Turn Signal Flasher	Ignition Hot Wire	Purple	14	✓	✓	✓	✓
53	Relay Ground- Horn	Ground	Black	18	✓	✓	✓	✓
54	Electric Choke	Ignition Hot Wire	Red	18	✗	✗	✓	✓
55	Third Brake Light	Switched Wire	Orange	18	✓	✓	✓	✓
56	Back-up Lights	Switched Wire	Green	18	✓	✓	✓	✓
57	Cruise Control Power	Ignition Hot Wire	Pink	18	✗	✗	✓	✓
58	B/up Light Switch Pwr	Ignition Hot Wire	Green	18	✗	✓	✓	✓
60	Extra Constant Hot	Constant Hot Wire	Orange	14	✗	✗	✗	✓
61	Extra Constant Hot	Constant Hot Wire	Blue	14	✗	✗	✗	✓
62	Relay Grd/Therm SG	Ground	Black	14	✗	✓	✓	✓
N/A	Speaker Wire x 2	Switched	Clear	16	✓	✓	✓	✓

Pre Connected Wires



Loose Wires (2 Ends)



**Wire Grouping Index**

Column Group			
#7	Dimmer Switch	Blue	12 Ga
#8	High Beam	Lght Green	14 Ga
#9	Low Beam	Tan	14 Ga
#18	Brake Switch to Turn Switch	White	14 Ga
#19	Neutral Safey Switch	Purple	12 Ga
#25	Front Right Turn Signal	Blue	16 Ga
#26	Front Left Turn Signal	Light Blue	16 Ga
#31	Ignition Coil	Pink	14 Ga
#32	Ignition Accessory	Brown	12 Ga
#33	Ignition Accessory	Orange	12 Ga
#34	Ignition Power	Red	12 Ga
#48	Right Rear Turn Signal	Green	14 Ga
#49	Left Rear Turn Signal	Yellow	14 Ga
#51	Emergency Flasher	Brown	14 Ga
#52	Turn Signal Flasher	Purple	14 Ga
#53	Relay Ground - Horn	Black	18 Ga

Accessory Group Switches			
#1	Electric Cooling Fan	Gray	14 Ga
#2	A/C Compressor	Black	14 Ga
#56	Back-Up Lights	Green	18 Ga

Constant Hot			
N/A	Extra Constant Hot	Blue	14 Ga
N/A	Extra Constant Hot	Orange	14 Ga

Headlight Group H-2			
#7	Dimmer Switch	Blue	12 Ga
#27	Front Parking Lights	Brown	16 Ga
#28	Headlight Switch Power	Red	12 Ga
#29	Tail Lights	Brown	14 Ga
#30	Power For Gauge Lights	Red	14 Ga

Brake Switch Group			
#17	Brake Switch Power	Orange	14 Ga
#18	Brake Switch to Turn Switch	White	14 Ga

**Wire Grouping Index**

Tail Group			
#29	Tail Lights	Brown	14 Ga
#39	Fuel Sending Unit	Pink	16 Ga
#42	Power Antenna Signal	Purple	18 Ga
#43	Power Antenna Signal	Red	18 Ga
#45	Dome Light Power	White	16 Ga
#46	Trunk Light Power	Green	16 Ga
#47	Electric Fuel Pump Power	Yellow	14 Ga
#48	Right Rear Turn Signal	Green	14 Ga
#49	Left Rear Turn Signal	Yellow	14 Ga
#55	Third Brake Light	Orange	18 Ga
#56	Back-up Lights	Green	18 Ga
N/A	Speaker Wire	Clear	16 Ga
N/A	Speaker Wire	Clear	16 Ga

Instrument Group			
#21	Temperature Sender	Green	18 Ga
#22	Oil Pressure Sender	Light Blue	18 Ga
#23	Tachometer	Purple	18 Ga
#30	Power for Gauge Lights	Red	14 Ga
#35	Power for Gauges	Red	16 Ga
#36	High Beam Indicator	Green	18 Ga
#37	Left Turn Indicator	Light Blue	18 Ga
#38	Right Turn Indicator	Blue	18 Ga
#39	Fuel Sending Unit	Pink	16 Ga

Accessory Group B+			
#3	Cigarette Lighter Power	Tan	14 Ga
#4	A/C - Heat Switch Power	Black	14 Ga
#5	Wiper Switch Power	Blue	16 Ga
#6	Electric Fan Switch Power	Gray	14 Ga
#57	Cruise Control Power	Pink	18 Ga
#58	Back-up Light Switch Power	Green	18 Ga

Radio Group			
#40	Radio Constant	Red	18 Ga
#41	Radio Ignition	Red	18 Ga
#42	Power Antenna Signal	Purple	18 Ga
N/A	Speaker Wire	Clear	16 Ga
N/A	Speaker Wire	Clear	16 Ga

Power Door D - 1			
#10	Right Door Lock	Yellow	14 Ga
#11	Right Power Window	Yellow	12 Ga

Power Door D - 2			
#12	Left Door Lock	Yellow	14 Ga
#13	Left Power Window	Yellow	12 Ga

Motor Group			
#2	A/C Compressor	Black	14 Ga
#14	Alternator Exciter	White	16 Ga
#16	Starter Battery Lug	Red	10 Ga
#19	Neutral Safety Switch	Purple	12 Ga
#20	Positive Side of Coil or HEI	Pink	14 Ga
#21	Temperature Sender	Green	18 Ga
#22	Oil Pressure Sender	Light Blue	18 Ga

Headlight Group H-1			
#1	Electric Cooling Fan	Gray	14 Ga
#8	High Beam	Light Green	14 Ga
#9	Low Beam	Tan	14 Ga
#24	Horn	Green	14 Ga
#25	Front Right Turn Signal	Blue	16 Ga
#26	Front Left Turn Signal	Light Blue	16 Ga
#27	Front Parking Lights	Brown	16 Ga

## 8 Circuit Standard

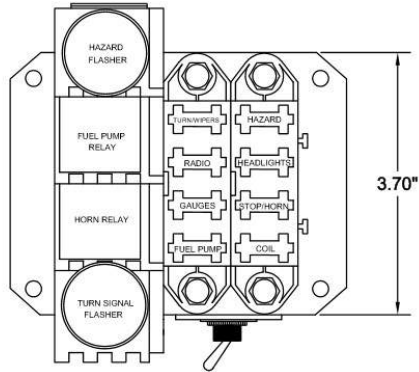

Coil Kill Switch

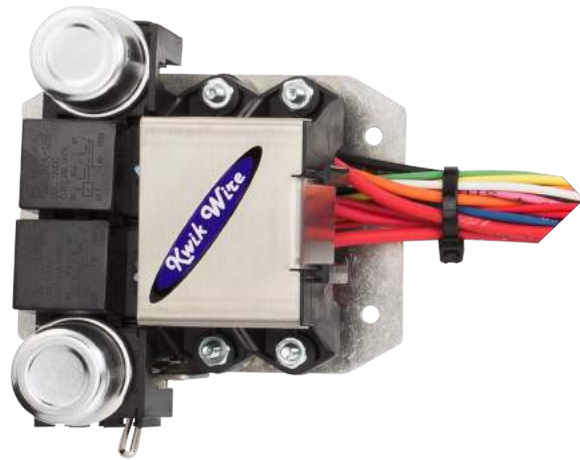
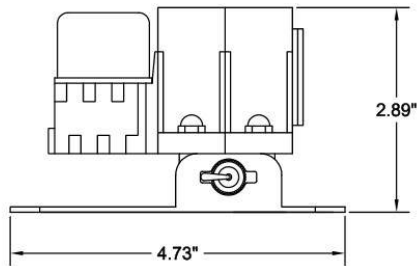

## 14 Circuit Standard

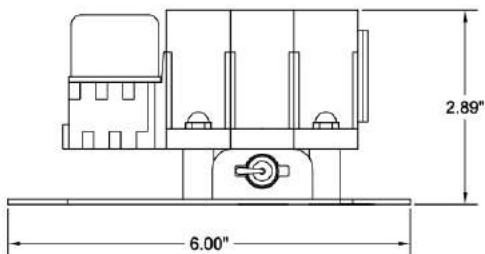
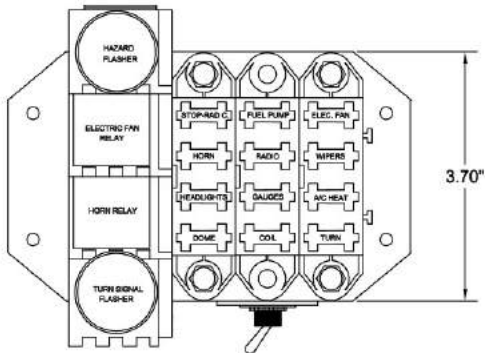

## 20 Circuit Standard

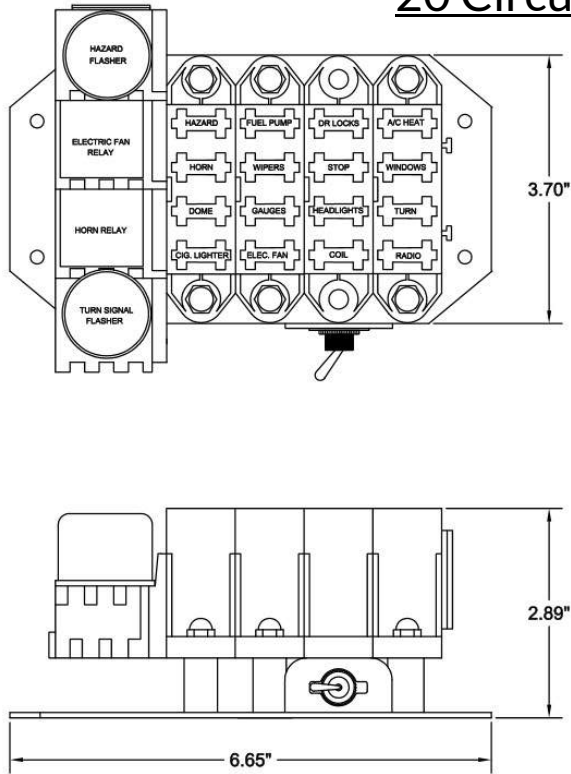

## 22 Circuit Standard

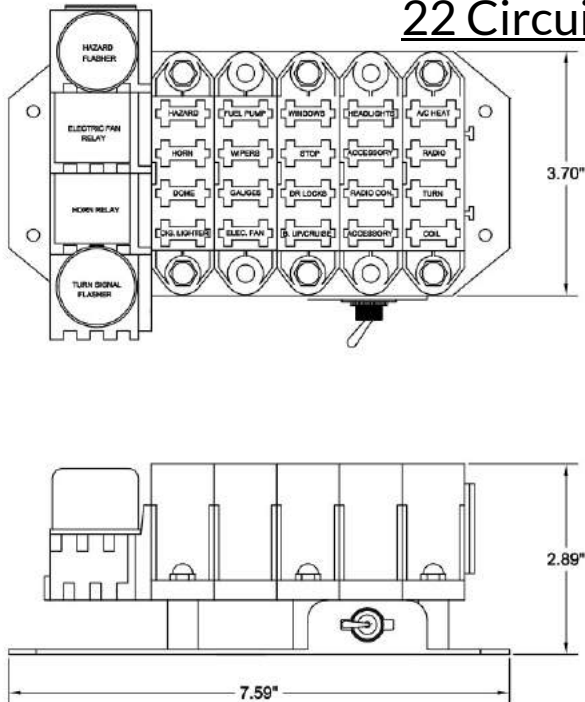

## **Recommended Tools**



### **Removal Tool - 56 Series**

This tool is useful in removing 56 (GM) series or any female tanged terminal from connectors. You can also use a precision flat blade screwdriver

This tool is specialized and can be ordered through our website. Part # 7025.



### **Removal Tool - Weather Pack**

This tool is useful in removing male and female weather pack terminals from connectors. It has a precise diameter so there is no easy substitute for it.

This tool is specialized and can be ordered through our website. Part # 7024.



### **Wire Cutter/Stripper**

This tool is useful in cutting and stripping wire for typical gauges including 10, 12, 14, 16, 18, and 20 AWG.

This tool is not specialized and can be purchased and any home center or hardware store. Our tool pictured is Part # 7030



### **All In One Multitool**

This tool is useful for cutting and stripping wire from 10 to 22 AWG. It can also crimp insulated and non insulated terminals and butt splices. This tool is not specialized and can be purchased from a local home center or ordered through our website. Part # 7026.



### **U-Barrel Crimper**

This tool is used to perform a "B" style crimp on wire and insulation. This is useful in crimping 56 series male and female terminal sizes 10 to 20 AWG. This tool is specialized and can be ordered through our website. Part # 7027.





### **Weather Pack Crimper**

This tool is used to perform a “B” style crimp on wire and insulation/seals. This is useful in crimping weather pack male and female terminal sizes 10 to 20 AWG and ratchets.

This tool is specialized and can be ordered through our website. Part # 10201.



### **3M Crimper**

This tool is useful in crimping insulated and non insulated terminals and butt splices. The crimping capacity is 10 to 22 AWG and is ratcheting.

This tool is specialized and can be ordered through our website. Part # 10200



### **Hammer Crimping Tool**

This tool is useful in crimping battery cable lugs, rings, and splices and handles 8 to 4/0 AWG This tool is specialized and can be ordered through our website. Part # 7029.

### **Other Recommended Tools**

- Heat Gun
- Testing Light
- Soldering Gun
- Battery Tester

# Terminal Removal

## 56 Series

### Female



Insert removal tool Part # 7025 or a flat blade precision screwdriver into keyway above terminal . The terminal tang seen underneath to the right will be bent up. Gently remove.



### Male

Insert removal tool # 7025 or a flat blade precision screwdriver into connector and push terminal tang (pointed out by bottom arrow) into itself. Gently remove terminal. These male terminals are a heavier gauge than the female and will require more force.

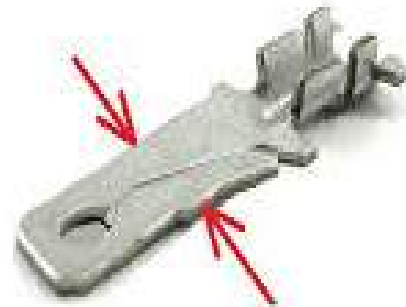

## Weather Pack Terminals

### Female and Male

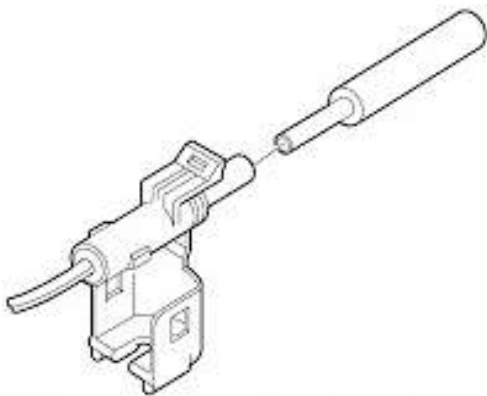

Insert removal tool # 7024 into terminal housing over the terminal and in as far as possible to bend opposing tangs inward and remove terminal. You may have to push wire towards tool for easier removal.

# Terminal Crimping

## U-Barrel Crimping

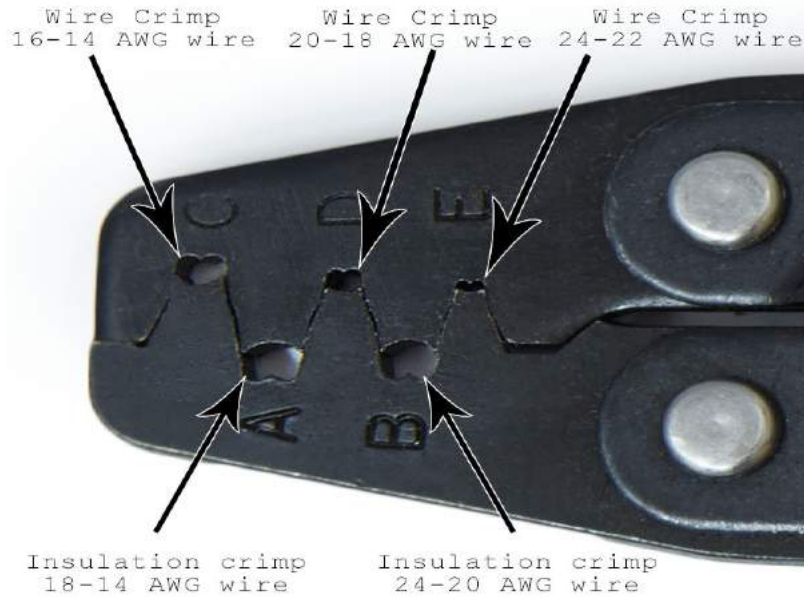

Use diagram to the left to match wire gauge with correct lettered jaw opening to crimp terminal to COPPER portion of wire.

The terminal base rests on curved portion of jaw with prongs facing towards "B" shaped crimp jaw.

Crimp slowly and firmly and repeat with insulation portion of terminal. For insulation crimp start with larger opening and finish with smaller to avoid breaking terminal.

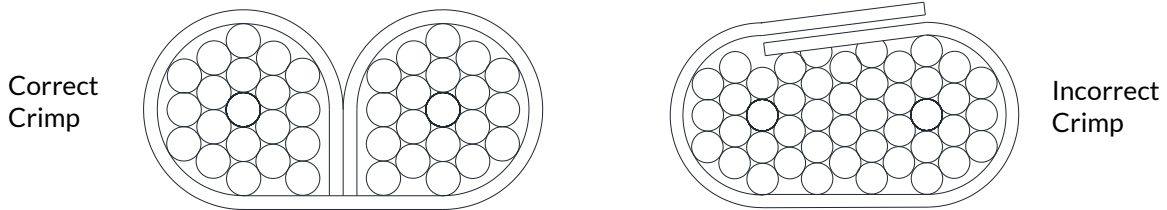

Crimp Cross Section

Completed



Be sure that no insulation is crimped and that wires are not protruding from crimp as to interfere with terminal connection.

We recommend protecting all crimps with shrink tube.

# Wire Splicing

## Uninsulated Butt Splice (See Kit Page 69)

The uninsulated butt splice is the most durable splicing method. Using this method you can ensure you have stripped and crimped the wire correctly. Another advantage to this method is that you can solder the connection and there is less chance for moisture retention unlike insulated. The most common sizes are 10-12, 14-16, and 18-22 AWG.



Crimping uses a square punch that sets wires into connector (see below). Place shrink tube (twice length of splice) on wire. Be sure bare wire reaches all the way into half of splice and that insulation butts up to edge of splice. Crimp wires on both sides of connector, solder, and then center shrink tube over connection and shrink.

All-In-One Multi Tool—PN: 7026



## Insulated Butt Splice

The insulated butt splice is another durable splicing method. This method has the advantage of being a splice and covering built into one application without needing an additional shrink tube covering. Some butt splices include an end flange that you can shrink.



These splices are more difficult as you cannot see the wire after it has been inserted and you must be careful not to crimp the wire insulation. A way to determine wire strip length would be to halve the distance from center of terminal to the flange.

Other drawbacks of this method are that you cannot solder splice and moisture can enter. The most common sizes are 10-12(Yellow), 14-16(Blue), and 18-22(Red)AWG.

# Wire Splicing

## Twist and Solder Method

The twist and solder method involves no mechanical fasteners to connect wires. This connection is held together by overlapping, twisting, and soldering wire (see below).

This method has many advantages including no moisture penetration after installing shrink tube and having small cross section size which reduces snagging/crowding of other splices in tight areas.

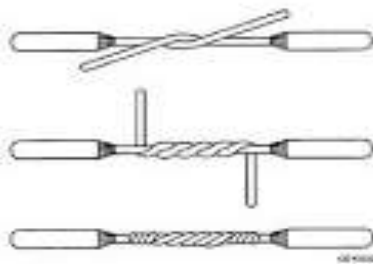

Begin by wrapping wires in opposite directions.

Continue by wrapping wire ends close together to form a neat splice.

Solder connection.

DO NOT USE:

- **Wire Nuts**

Wire nuts are engineered for solid core wire and non-mobile applications. In motion or during vibrations a wire nut can loosen and loose connection.



- **Parallel Twist w/ Electrical Tape**



Will loosen from either temperature fluctuations, age, or may not be wrapped tight because of fingertip oil on tape surface.

- **Scotch Locks**



This connection relies on an aluminum blade being poked through both wires and insulation using a pliers and then locking a plastic cap. This is meant for an emergency and only temporary repair.



# Catalog

Headlight Switch Part # 70701



Headlight Switch Part # 70701A



Dimmer Switch Part # 70705



Ignition Switch Part # 70702 B



Wiper Switch Part # 99002



Battery Disconnect Part # 1003



Turn Signal Switch Part # 6020



Fuel Injection Kits Now Available.

GM  
MOPAR  
FORD  
And MORE

Please contact us for more info.

Horn Switch Part # 3054



HEI Connector Power & Tach Part # 450



Mechanical Stop Switch Part # 70704



Halogen Relay Kit Part #1100



12V Power/USB Outlet Part # 675CB



30A Relay Kit Part # 2078



Dash Harness



# MAG DADDY™

MAGNETIC FASTENERS



## **Magnetic Cable Tie - Part # 62411**

- Magnet pull strength 16 lbs
- Standard cable tie slot
- Will rotate 360°

## **Magnetic Cable Holder**

### **1" - Part # 62421**

- Magnet pull strength 26 lbs
- Wires can be easily added and removed
- Will rotate 360°



### **3/4" - Part # 62419**

- Magnet pull strength 16 lbs
- Wires can be easily added and removed
- Will rotate 360°

### **1/2" - Part # 62409**

- Magnet Pull Strength 16 lbs
- Wires can be easily added and removed
- Will rotate 360°



## **Magnetic Cable Holder - Part # 62423**

- Pull strength 24 lbs
- Wires can be easily added and removed
- 1" X 7/16" base
- Will rotate 360°
- Designed for curved surface mounting



## **Magnetic Plate - Part # 96702**

- Pull strength 26lbs
- Holes allow for glued and sewn attachment.
- 2" LX 1.2" W " X 1/4" H
- Great for headliner installation

# Tools

## **56 Series Removal Tool**

Removes most GM terminals from the connector



## **Weather Pack Removal Tool**

Removes all weather pack terminals from the connector  
Part # 7024



## **3M Ratcheting Crimper**

Crimps  
10 - 22 Gauge Wire  
Part # 10200



## **Weather Pack Ratcheting Crimper**

Crimps  
16 - 12 Gauge Wire  
Part # 10201



**All In One Crimper**  
Crimps, Strips, and Cuts  
10 - 22 Gauge Wire  
Part # 7026



**U-barrel Crimper**  
Crimps U-barrel terminals  
14 - 24 Gauge Wire  
Part # 7027



**Precision Wire Strippers**  
10 - 20 Gauge Wire  
Part # 7030





# Connector and Terminal Kits

## Standard Non-Insulated Butt Connectors Kit

Part # 177

25 Pcs- 10-12 Ga.

25 Pcs- 18-22 Ga.

50 Pcs-- 16-14 Ga.

3/16" and 1/4" Shrink Tube



## Weather Pack Tray

1 Position 4 pcs

2 Position 4 pcs

3 Position 4 pcs

4 Position 4 pcs

6 Position 4 pcs

Male Terminals 75 pcs

Female Terminals 75 pcs

Green Seals 75 pcs

Gray Seals 75 pcs

Removal tool 1 pc

Part # 3019



## 56 Series Pack Tray

1 Position 4 pcs

2 Position 6 pcs

3 Position 4 pcs

4 Position 4 pcs

5 Position 4 pcs

6 Position 4 pcs

4 Sets HEI Connectors

1 Set Ignition GM Connectors

4 pcs of GM Alternator Connector

Male Terminals 95 pcs

Female Terminals 115 pcs

Removal tool 1 pc

Part # 3019-56



# Wire Loom

Lightweight and durable, it maintains its flexibility for conforming to irregular shapes and bends during installation. The low-profile design is great for channeling and protecting wires that run under the carpet or in the headliner of automobiles.

**Wire Channel Loom**

1 3/4" self-wrappable sleeve  
Part # F6Z1.75BK



**Fabric Heatshrink Tubing**

Fabric heatshrink tubing, a unique mixture of polyolefin and polyester yarns, is the ideal way to form the only shrinkable fabric of its kind. The woven construction makes this product extremely flexible and resistant to trapping water, heat and humidity. Provides outstanding abrasion, chafing and cutthrough protection, even at high temperatures.

Size	Part #
1/2"	H2F0.48BK
3/4"	H2F0.79BK
1 1/2"	H2F1.58BK
2 3/4"	H2F2.75BK

Size	Part #
1/4"	FGN0.25
3/8"	FGN0.38
1/2"	FGN0.50
3/4"	FGN0.75
1"	FGN1.00

**Insultherm Loom** Available in a wide range of diameters. It cuts cleanly with scissors and installs easily over a variety of applications to either deflect or retain heat in environments up to 1,200°F.

**Split Braided Loom**

Semi-rigid braided construction of this loom makes it the ideal solution for situations where ease of installation is of primary importance.

The lateral split allows the tube to open up to accommodate a wide variety of bundling requirements, and the semi-rigid braid configuration simply closes around the entire installation without the need for any additional fasteners (velcro, tape, etc.)



Size	Part #
1/4"	SL14
3/8"	SL38
1/2"	SL12
3/4"	SL34

## Polyolefin Heat Shrink Tubing 4 foot lengths



A high quality material which shrinks to 1/2 the expanded size. This material is vary stable and can be stored for extended periods without shrinking. Temperature rating of -67 F to 275° F.

### Without Sealant

Size	Part #
3/16"	241
1/4"	242
3/8"	243
1/2"	244
3/4"	245
1"	246

### With Sealant

Size	Part #
1/4"	247
3/8"	248
1/2"	249
3/4"	250

Harness Registration Card or @ [kwikwire.com/wire-harness-registration](http://kwikwire.com/wire-harness-registration)

Name/Company \_\_\_\_\_

Address \_\_\_\_\_

City \_\_\_\_\_ State \_\_\_\_\_ Zip \_\_\_\_\_

Phone \_\_\_\_\_

Serial # \_\_\_\_\_ (found on the back of fuse panel)

Kwik Wire  
N4936 Hwy V  
Fond Du Lac, WI 54937

Phone: 920-921-2637

Email: [corys@kwikwire.com](mailto:corys@kwikwire.com)

*Electrify Your Ride*

Don't Forget  
to Complete  
Wire Harness  
Registration!



# 2019 / 2020 Show Schedule



Run To The Sun Meet  
 March 21-23/19-21  
 Myrtle Beach , SC  
 South End



Spring Carlisle  
 April 24-28/22-26  
 Carlisle, PA



Spring Jefferson Swap Meet  
 April 26-28/24-26  
 Jefferson, WI  
 YJ 147-152 Yellow field

Fall Jefferson Swap Meet  
 September 27-29/25-27  
 Jefferson, WI  
 YJ147-152 Yellow Field



Back To The 50's  
 June 21-23/19-21  
 St Paul, MN  
 Under The grandstand I4-5



Good Guys  
 July 12 - 14/10-12  
 Columbus, OH



Right Coast Nationals  
 July 19-21/17-19  
 Syracuse, NY  
 Center Progress Building



NSRA Street Rod Nationals  
 August 1-4/2-5  
 Louisville, KY  
 Space 1219



Frog Follies  
 August 23-25/21-23  
 Evansville, IN  
 Building A Front



Cajun Street Rod Nationals  
 October 4-6/2-4  
 Gonzales, LA



Cruizin The Coast  
 October 10-12/8-10  
 Biloxi, MS  
 A101



Electrify Your Ride

PLEASE  
 PLACE  
 STAMP  
 HERE

Kwik Wire  
 N4936 Hwy V  
 Fond Du Lac, WI 54937